

V10、V20 Series Vane Pumps—For Industrial Equipment

Product show and brief introduction

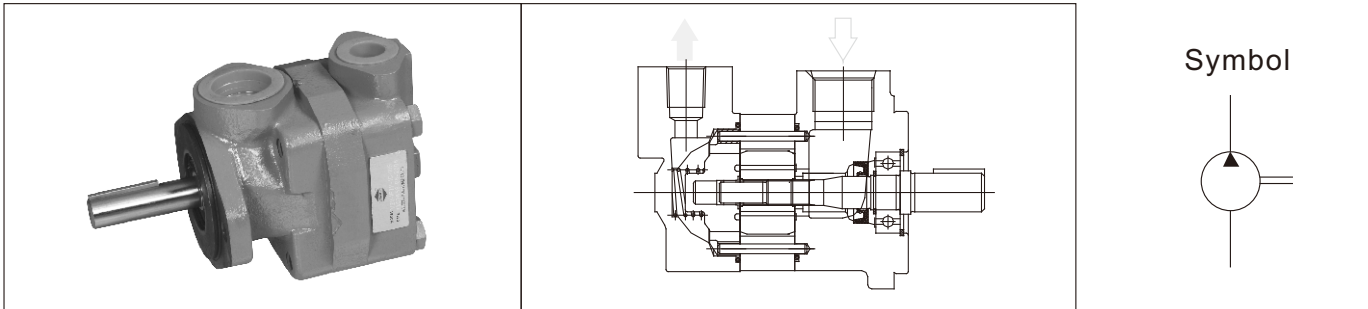

Model Code

(F3-)	V10	-P	7	S	-1	C	20	-L
Prefix	Series	Inlet port connections	Code	Outlet port connections	Shafts	Outlet Positions	Design	Rotation
Omit-Usting antiwear oil water glycol fluid	V10	P-1" NPT thread S-1.3125-12 straight thread B-G1" thread	1,2,3,4, 5,6,7	P-1/2" NPT thread S-0.750-16 straight thread B-G1/2" thread	1-Str,Key 11-Spline 38-11tooth -3/4" OD.	(Viewed from cover end of pump) A-Opposite inlet port B-90°CCW from inlet C-In line with in inlet D-90°CW from inlet	20	(Viewed from shaft end of pump) L-Left hand for counter clockwise R-Right hand for clockwise
F3-Phosphate ester fluid	V20	P-1-1/4" NPT thread S-1.625-12 straight B-G1-1/4" thread	6,7,8,9, 10,11,12, 13,14	P-3/4" NPT thread S-1.1875-12 straight thread B-G3/4" thread	62-spline (V20 only)		10	

Specification

Model	Code	Geometric Displacement mL/r	Using anti-wear oil or phosphate ester fluid		Using water glycol fluid		Using water-in-oil emulsion		
			Max.pressure MPa	Max.Speed r/min	Max.pressure MPa	Max.Speed r/min	Max.pressure MPa	Max.Speed r/min	
V10	1	3.3	17.2	4800	12.4	1800	10.3	1800	
	2	6.6		4500					
	3	9.8		4000					
	4	13.1		3400					
	5	16.4		3200					
	6	19.5	15.2	3000			10.9		
	7	22.8	13.8	2800					
V20	6	19.5	17.2	3400	12.4	1800	10.9	1800	
	7	22.8		3000					
	8	26.5		2800					
	9	29.7							
	10	30.0							
	11	36.4	2500						
	12	39	15.2	2400			10.9		9.3
	13	42.4							
14	45								

Performance Characteristics

Typical flows at 49°,oil at 26cSt(38°),0MPa

V10

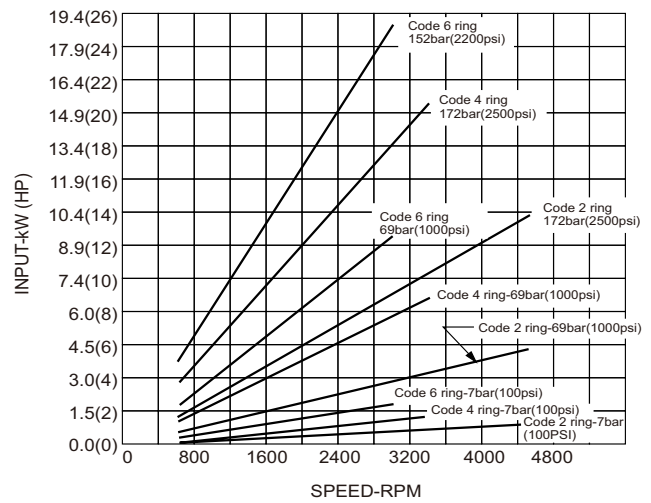
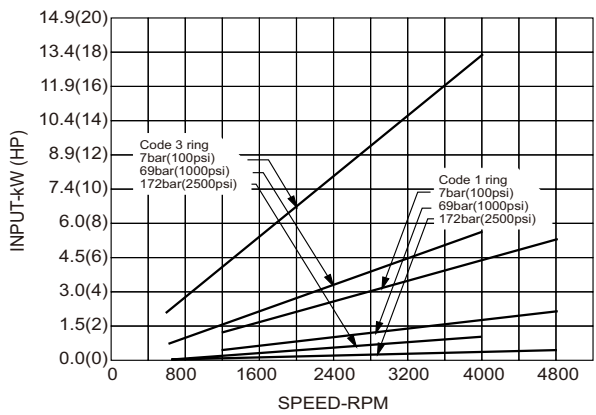
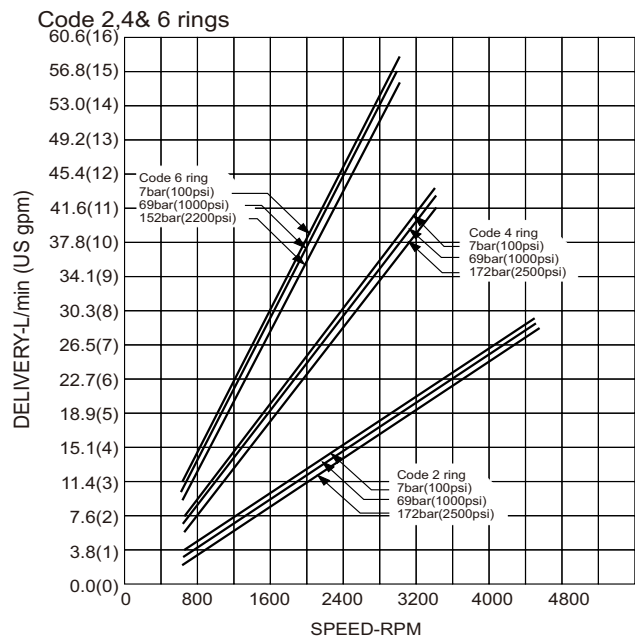
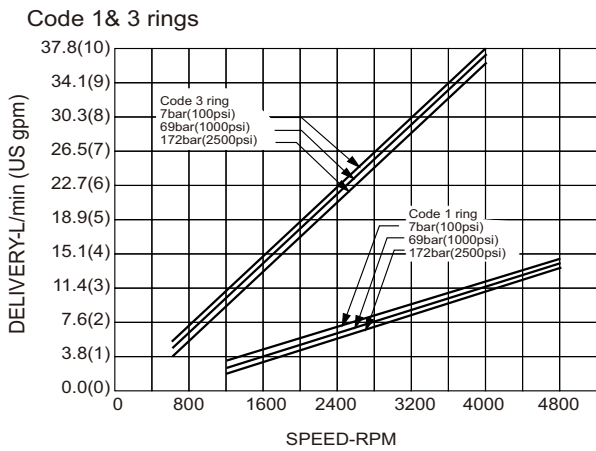

Performance Characteristics

Typical flows at 49°,oil at 26cSt(38°),0MPa

V10

Code 5 & 7 rings

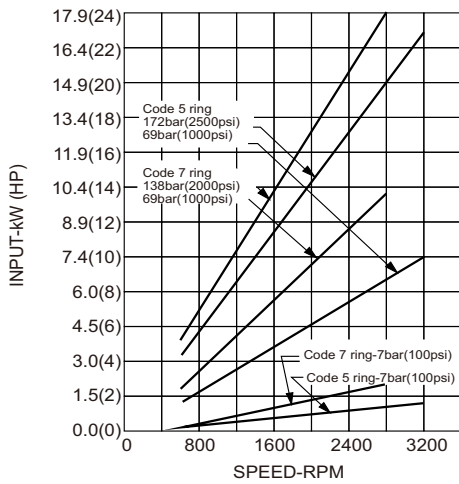
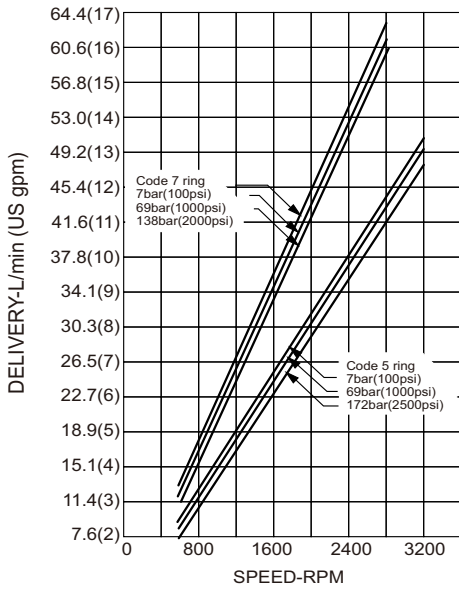

V20

Code 6,8 & 12 rings

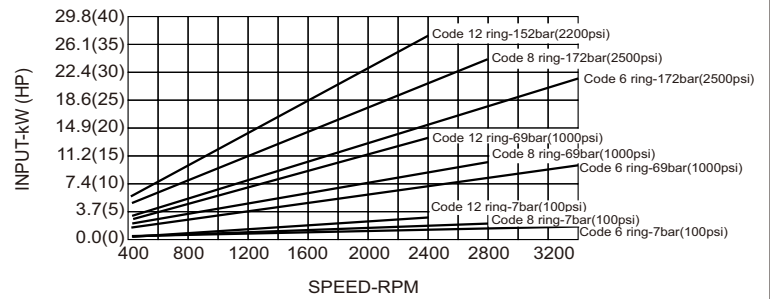
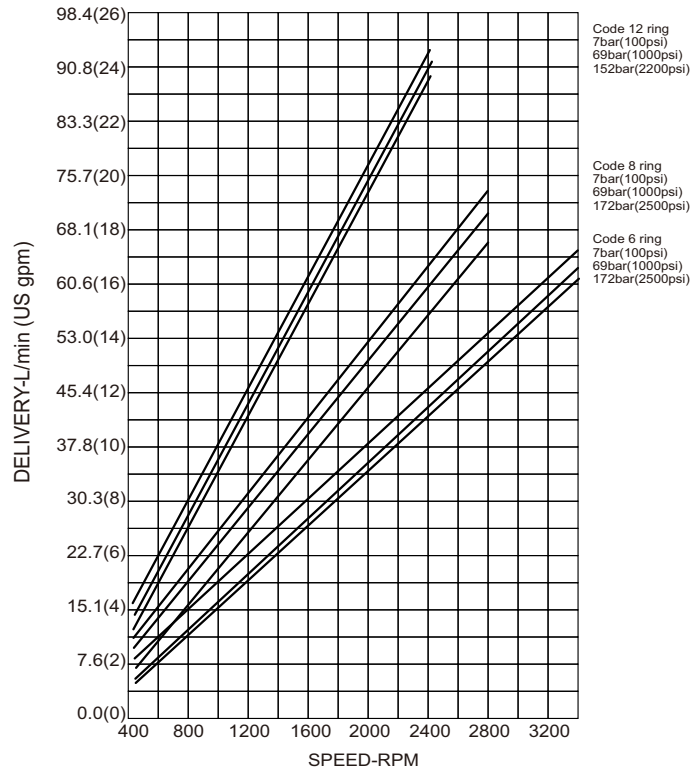

Performance Characteristics

Typical flows at 49° oil at 26cSt(38°),0MPa

V20

Code 7 & 13 rings

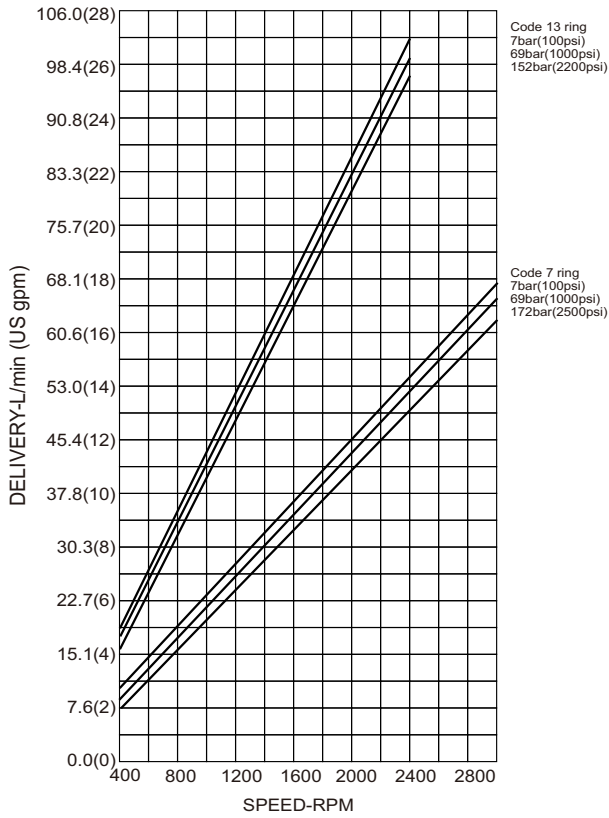

Code 9 & 11 rings

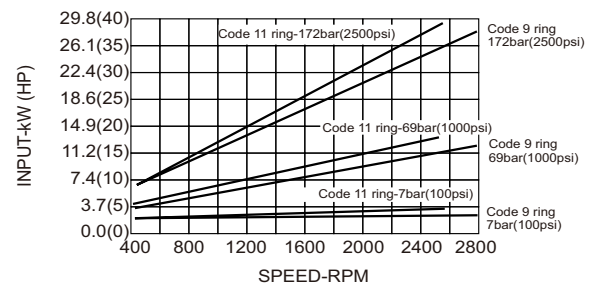
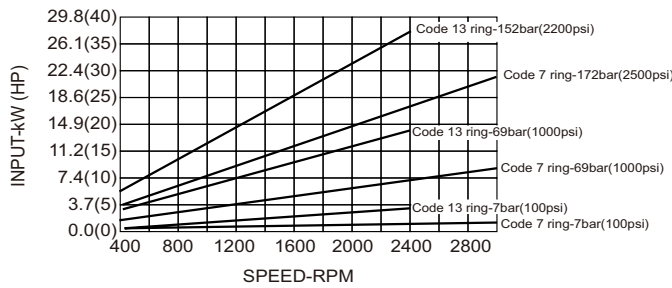
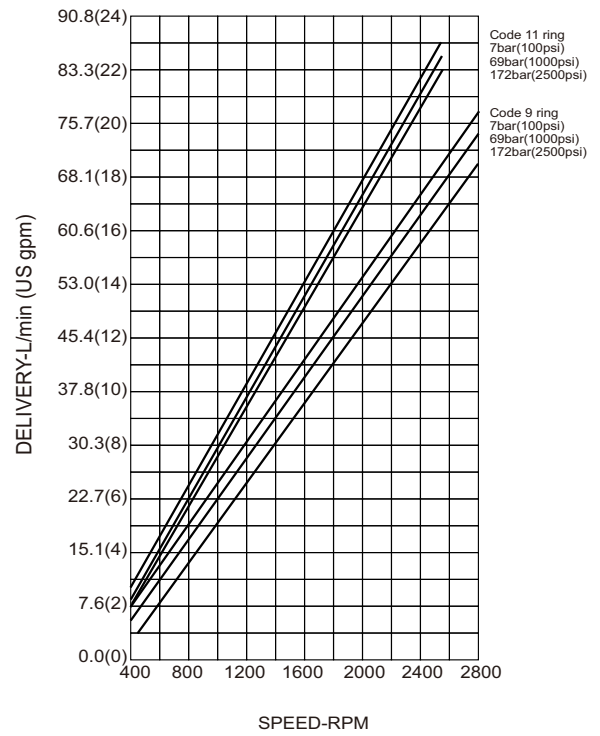

Installation dimensions

V10

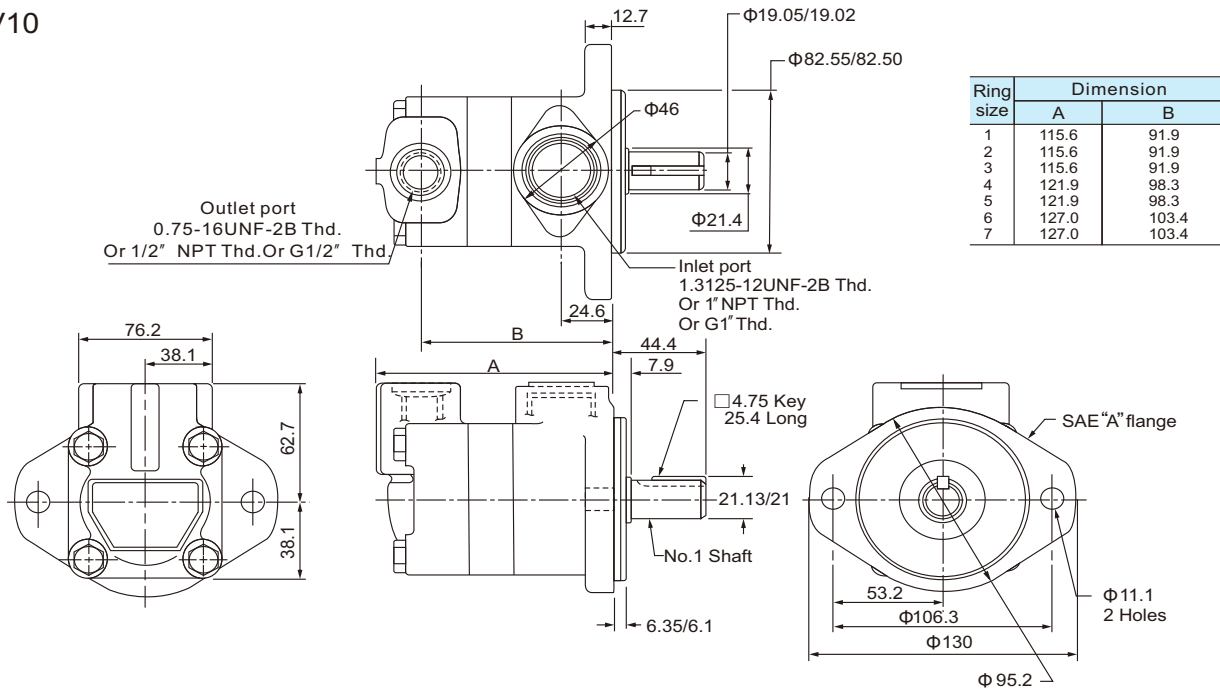

V20

