

4WEH/4WH

Directional spool valves, pilot-operated, with hydraulic or electro-hydraulic actuation

■ Product show and brief introduction

Sizes 10...32
 Component series 4X;6X;7X
 Maximum operating pressure 35MPa
 Maximum flow 1100 L/min



■ Features

- For subplate mounting
- Wet-pin DC or AC solenoids, optional
- With or without fault detection button
- Electrical connection as individual or central connection
- Spring or pressure centring, spring end position or hydraulic end position
- Pilot throttling regulator
- Stroke limit of main control spool
- On port P of the main valve, there is a pilot pressure insert
- When the control pressure exceeds 25 Mpa, the regulator reduces the pilot pressure
- Cartridge orifice reduces oil supply to pilot valve

Ordering details

1	2	3	4	5	6	7	8	9	10	11
						/	6E			

NO.	Version	Code	Explanation	
1	Highest pressure	No Code	To 28MPa	
		H-	To 35MPa	
2	Types of operation	4WEH	Electro-hydraulic	
		4WH	Hydraulic	
3	Nominal size	10	Size 10	
		16	Size 16	
		22	Size 25,standard type	
		25	Size 25,high power type	
		32	Size 32	
4	Spool return	No Code	Springs	
		H	Hydraulic	
5	Symbols		See page	
6	Series	4X	For size 10	
		6X	For size 25 (high power type) and size 32	
		7X	Size 16 and size 25(standard type)	
7 ^①	Pilot vavle spool return	No Code	Spring return	Spool return in the pilot vavle for 2-position vavle and 2 solenoids only possible with spools C,D,K,Z and hydraulicspool return in the main valve .
		O	Without spring return	
		OF	With Orientation Organ	
8 ^①		6E	High-performance valve	
9 ^①	Input voltage	W220	220V/50Hz,240V/60Hz	
		W110	110V/50Hz,120V/60Hz	
		RAC220	220V/50Hz,240V/60Hz	
		RAC110	110V/50Hz,120V/60Hz	
		G12	12V	
		G24	24V	
		G48	48V	
10 ^①	Pilot valves hand override	N9	With protected hand override (standard)	
		N★	With hand override	
11 ^①	Pilot oil supply and drain line	No Code	Pilot oil supply external , pilot oil drain external	
		E	Pilot oil supply internal , pilot oil drain external	
		T	Pilot oil supply external , pilot oil drain internal	
		ET	Pilot oil supply internal , pilot oil drain internal	

Ordering details

12	13	14	15	16	17	18	19	20	21
		/							

NO.	Version	Code	Explanation
12 ^①	shifting time★ adjustment	No Code	Without shifting time adjustment
		S	Shifting time adjustment as meter-in control
		S2	Shifting time adjustment as meter-out control
13 ^①	Electrical connections	K4	Individual connections with component plug ISO4400 with plug-in connector
		DL	Central connections Terminal box with cable connector,with indicator light
14 ^①	Plug-in connector	No Code	Without plug-in connector
		Z4	With guadrate plug-in connector
		Z5L	Guadrate plug-in connector with indicator light
		F6L	With waterproof plug-in connector ^②
15	Moving space Adjustment ^③	No Code	Without moving space adjustment
		10	A and B side with moving space adjustment
		11	A side with moving space adjustment
		12	B side with moving space adjustment
16 ^①	Throttle position	No Code	Without cartridge throttle
		P	Active in the P line
		A	Active in the A line
		B	Active in the B line
		T	Active in the T line
17 ^①	Throttle diameter	No Code	Without cartridge throttle
		08	Throttle ϕ 0.8 mm
		10	Throttle ϕ 1.0 mm
		12	Throttle ϕ 1.2 mm
18 ^①	Pre-load valve ^④	No Code	Without pre-load valve
		P	With pre-load valve
19	Pressure★ reducing valve	No Code	Without pressure reducing valve
		D3	With pressure reducing valve between mail valve and pilot valve
20	Seal material	No Code	NBR seals
		V	FKM seals
21		No Code	Futher details in clear text

Note:

- ① Only apply on Electro-hydraulic Operated Directional Valve; ③ Only apply on size 16 ;
 ② Waterproof degree of plug-in connector is above IP65; ④ Not apply on size 10 and size 25 (standard type);
 ★ Please consult us when you choose this application.

Symbols

Sort	2-position valve		3-position valve	
	Spring return	Hydraulic return	Spring return	Hydraulic return
4WH				
4WEH				
	—			
	—			

Spool return

	Springs		Hydraulic		Springs		Hydraulic ^①	
X=external ; Y=external	4WEH.../... 	4WEH...H.../... 	4WEH...H.../O... 	4WEH...H.../OF... 	4WEH.../... 	4WEH...H.../... 	4WEH.../... 	4WEH...H.../...
X=internal ; Y=external	4WEH.../...E... 	4WEH...H.../...E... 	4WEH...H.../O...E... 	4WEH...H.../OF...E... 	4WEH.../...E... 	4WEH...H.../...E... 	4WEH.../...E... 	4WEH...H.../...E...
X=external ; Y=internal	4WEH.../...T... 	4WEH...H.../...T... 	4WEH...H.../O...T... 	4WEH...H.../OF...T... 	4WEH.../...T... 	4WEH...H.../...T... 	4WEH.../...T... 	4WEH...H.../...T...
X=internal ; Y=internal	4WEH.../...ET... 	4WEH...H.../...ET... 	4WEH...H.../O...ET... 	4WEH...H.../OF...ET... 	4WEH.../...ET... 	4WEH...H.../...ET... 	4WEH.../...ET... 	4WEH...H.../...ET...

NOTE:

① At present , this code only apply on size 16, size 25 (high power type) and size 32.

● For hydraulic middle 3-position valve , it's preferential choice for pilot oil supply external and drain external .

Function, section

Type: 4WEH 10 E 4X/6EG24N9K4Z5LH

Initialization

Pilot valve at middle position. Main spool at two end pass oil box .

Work state

Solenoid “a” gets through electricity. Pilot spool 10 moves to left to control oil from pilot valve’s P port to B port . After that , the oil enter main spool’s left antrum 4 . It drives main spool 2 to move to right after conquering the spring power of spring 3.2 . At final , it comes true P pass to B and A pass to T for main valve. Solenoid “b” gets through electricity . The P pass to A and B pass to T for main valve.

Main valve spring return

Solenoid loses electricity. The main spool return to original position under spring power of spring 3.1 or 3.2.

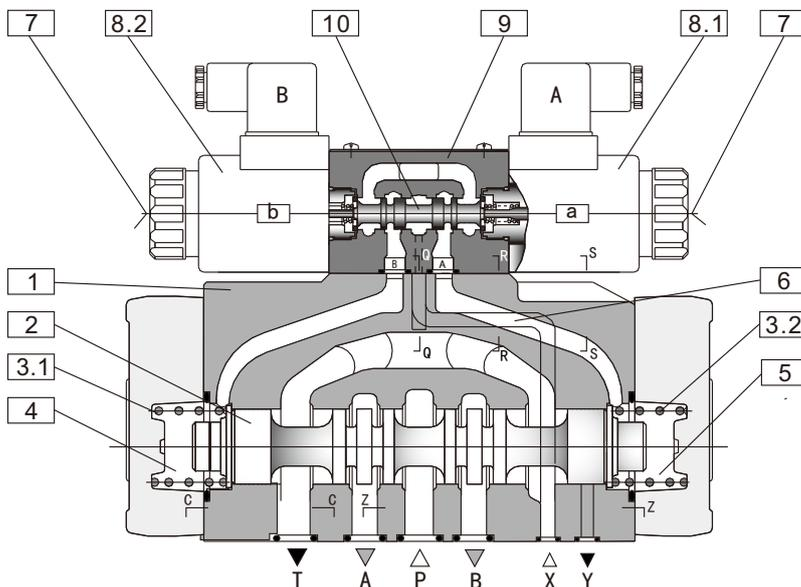

Main valve hydraulic return

The main spool’s two end pass to control oil . After solenoid gets through electricity , one end controls oil to return to oil box and main spool to move . It comes true oil road’s shift for main valve. After solenoid loses electricity , the main spool’s two end return under hydraulic power.

Pilot control type

4WEH10...

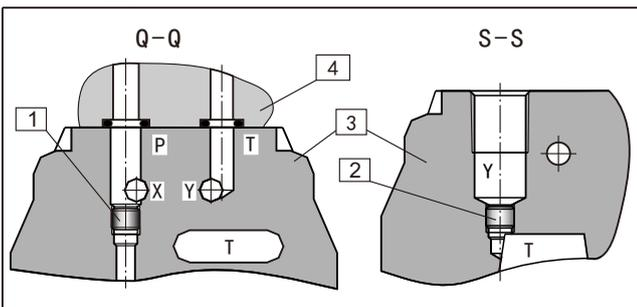

Installation	No code	ET	E	T
Screw plug 1	○	○	×	×
Screw plug 2	○	×	○	×

4WEH16...

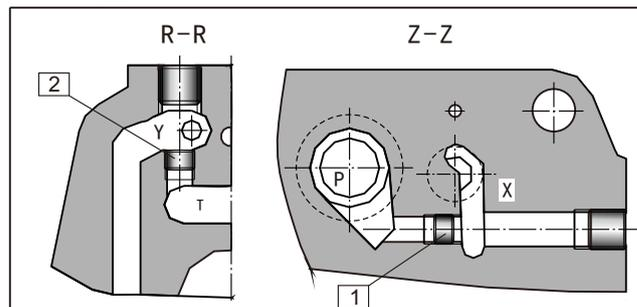

Installation	No code	ET	E	T
Screw plug 1	○	○	×	×
Screw plug 2	○	×	○	×

4WEH22...

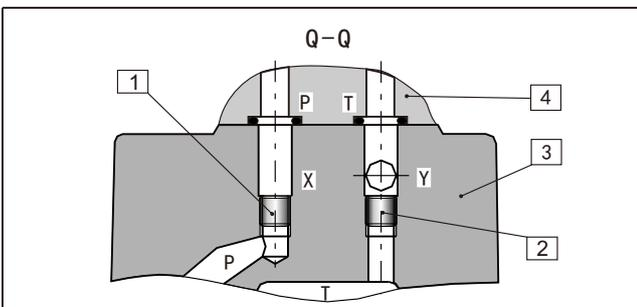

Installation	No code	ET	E	T
	○	○	×	×
	○	×	○	×

4WEH25...

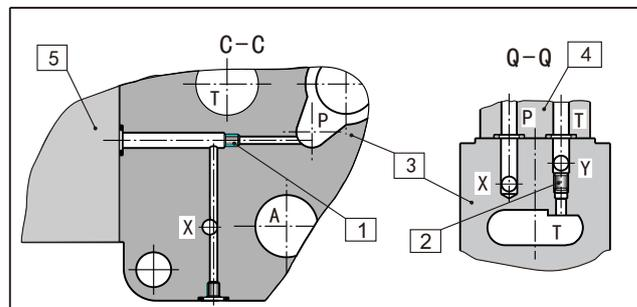

Installation	No code	ET	E	T
Screw plug 1	○	○	×	×
Screw plug 2	○	×	○	×

Pilot control type

4WEH32 ...

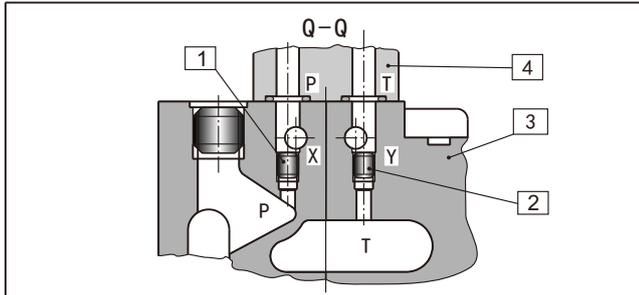

Installation	No code	ET	E	T
Screw plug 1	○	○	×	×
Screw plug 2	○	×	○	×

Note: "○" express installation.
"×" express without installation.

The dimension of the Screw plug 1 and 2 is Rc1/16 (JB/ZQ4446-86)

4WEH...and 4WH...

The pilot oil supply is sourced externally via channel X from a separate circuit . And the pilot oil drain is led externally via channel Y to tank .

4WEH...E...

The pilot oil supply is sourced internally from channel P of the main valve . And the pilot oil drain is led externally via channel Y to tank . Port X in the subplate is plugged .

4WEH...ET...

The pilot oil supply is sourced internally from channel P of the main valve . And the pilot oil drain is led internally via channel T to tank . Port X and Port Y in the subplate is plugged .

4WEH...T...

The pilot oil supply is sourced externally via channel X from a separate circuit . And the pilot oil drain is led internally via channel T to tank . Port Y in the subplate is plugged .

Shifting time adjustment

In order to adjust the shifting time adjustment , there is a modular check relief valve 2 (Type: Z2FS6) during pilot valve 1 and Main valve 3. Adjustment way: Circumgrate adjustment bolt as clockwise, the main valve's shift time is longer. Otherwise, shifting time is shorter. Inlet relief 4 changes to outlet relief 5's way: Dismantle Pilot valve. Reassembling modular type check relief valve to circle longshaft to circumgrate 180. Then assembling Pilot valve again.

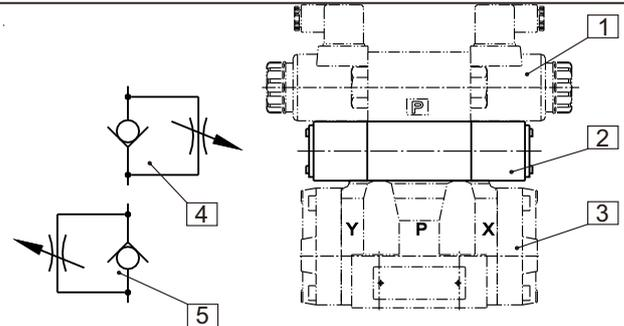

Pilot pressure and flow adjustment

In order to reduce impact of main valve shift, it must install modular type fix rate reducing valve 6 when control oil pressure more than 25MPa. Reduce rate is 1:0.66. After assembling fix rate reducing valve, min. control oil pressure must improve 1/0.66=1.515 times in technical data.

It can't install fix rate reducing valve when control type chooses pilot oil drain internal, installs prefill valve(P0.45) and control pressure reduces to 0.3MPa. It can install throttle 7 when control oil's flow need Limit. There are 0.6,0.8,1.0,1.2(mm)four dimensions for throttle aperture.



Pre-load valve

In order to ensure lowest control oil pressure, it must install a pre-load valve at P port when control oil inside supply and there is un-load pass way.

After installing prefill valve, the total pressure lose of valve is the sum for main valve's and pre-load valve's pressure lose.

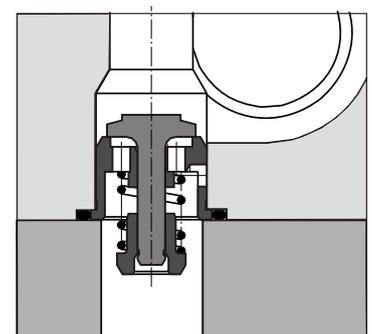
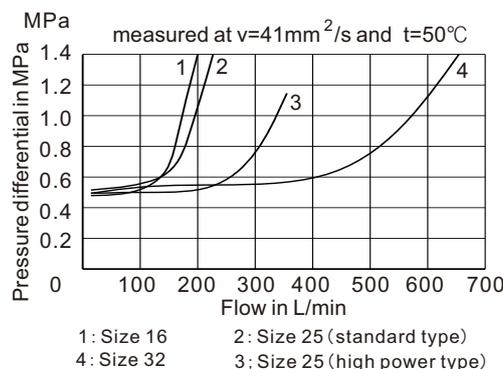

Technical data

Nominal size (ordering code)				...10...	...16...	...22...	...25...	...32...
Max . operating pressure								
4WEH	Port P、A、B	4WEH	MPa	28	28	28	—	28
		H-4WEH	MPa	35	35	35	35	35
	Port T	Pilot oil drain external	MPa	31.5	25	25	25	25
		Pilot oil drain internal	MPa	21 (DC) ; 16 (AC)				
	Port Y	Pilot oil supply external	MPa	21 (DC) ; 16 (AC)				
4WH			MPa	25	25	21	25	25
Max . pilot pressure				25	25	21	25	25
Min . pilot pressure								
Pilot oil supply internal (For spool D, K,E,J,L,M,Q, U,W)	3-position valve spring-centered	H-4WEH	MPa	1.0	1.4	1.25	1.3	0.85
		4WEH	MPa	1.0	1.4	1.05	1.3	0.85
Pilot oil supply external	3-position valve hydraulic-centered		MPa		1.4		1.8	0.85
	2-position valve spring return	H-4WEH	MPa	1.0	1.4	1.4	1.3	1.0
		4WEH	MPa	1.0	1.4	1.1	1.3	1.0
	2-position valve hydraulic return		MPa	0.7	1.4	0.8	0.8	0.5
Pilot oil supply internal (For spool C,F,G,H,P,T,V,Z,D)			MPa	0.45	0.45	0.45	0.45	0.45

Pilot oil volume for the main valve shifting								
3-position valve , spring-centred			cm ³	2.04	5.72	7.64	14.2	29.4
2-position valve			cm ³	4.08	11.45	15.28	28.4	58.8
3-position valve hydraulic-centred	From middle position to position a	WH	cm ³	—	2.83	—	7.15	14.4
		WEH	cm ³	—	2.83	—	7.15	14.4
	From position a to middle position	WH	cm ³	—	5.72	—	14.18	29.4
		WEH	cm ³	—	2.9	—	7.0	15.1
	From middle position to position b	WH	cm ³	—	5.72	—	14.18	29.4
		WEH	cm ³	—	5.72	—	14.15	29.4
	From position b to middle position	WH	cm ³	—	8.55	—	19.88	43.8
		WEH	cm ³	—	2.83	—	5.73	14.4

Pilot oil flow for the shortest shifting time	L/min	about 35	about 35	about 35	about 35	about 45
---	-------	----------	----------	----------	----------	----------

Weight (data only for reference)						
Single solenoid valve	kg	6.4	8.5	11.5	17.6	40.5
Double solenoids valve spring-centred	kg	6.8	8.9	11.9	18.0	41.0
Double solenoids valve hydraulic-centred	kg	6.8	8.9	11.9	19.0	41.0
Hydraulic operated directional valve	kg	6.5	7.3	10.5	16.5	39.5
Shifting time adjustment set	kg	0.8	0.8	0.8	0.8	0.8
Pressure reducing valve	kg	0.4	0.4	0.4	0.4	0.4

Working environment temperature range	°C	-30 TO +50				
---------------------------------------	----	------------	--	--	--	--

Installation position	Valves for HC,HD,HK,HX,HZ,HY symbols must install flatly . It can choose freely for others.					
-----------------------	--	--	--	--	--	--

Shifting times

Nominal size 10 AC (∼) and DC (=)										
Pilot pressure		MPa	7		14		21		25	
Voltage type			∼	=	∼	=	∼	=	∼	=
Shifting time of the valve from neutral position to shifted position	三位阀	ms	30	65	25	60	20	55	15	50
	二位阀	ms	35	80	30	75	25	70	20	65
Shifting time of the valve from shifted position to neutral position	三位阀	ms	30	30	30	30	30	30	30	30
	二位阀	ms	35	40	30	35	25	30	20	25

Nominal size 16 Ac (∼) and DC (=)											
Pilot pressure		MPa	7		14		21		25		
Voltage type			∼	=	∼	=	∼	=	∼	=	
Shifting time of the valve from neutral position to shifted position	3-position valve spring-centred	ms	25-30	40	25-30	40	25-30	40	20-25	40	
	2-position valve	ms	30-35	55	30-35	55	30-35	55	25-30	50	
	3-position valve hydraulic centred	o to a	ms	30	40	30	40	30	35	30	35
		o to b	ms	30	40	30	40	30	40	30	40
Shifting time of the valve from shifted position to neutral position	3-position spring-centred	ms	35-50	45	35-50	45	30-45	40	30-45	35	
	2-position valve	ms	35-50	45	35-50	45	30-45	40	30-45	35	
	3-position valve hydraulic centred	ms	25-35	20	25-55	20	20-35	20	20-35	20	

Nominal size 25 (Standard, AC (∼) and DC (=)										
Pilot pressure			3.5		7		14		21	
Voltage type			∼	=	∼	=	∼	=	∼	=
Shifting time of the valve from neutral position to shifted position	3-position valve	ms	50	100	40	80	35	65	30	60
	2-position valve	ms	100	160	90	110	75	95	70	85
Shifting time of the valve from shifted position to neutral position	3-position valve	ms	35-50	35	35-50	35	35-50	35	35-50	35
	2-position valve	ms	90-105	95	65-80	70	65-80	55	45-60	50

Nominal size 25 (High power standard, Ac (∼) and DC (=)											
Pilot pressure		MPa	7		14		21		25		
Voltage type			∼	=	∼	=	∼	=	∼	=	
Shifting time of the valve from neutral position to shifted position	3-position valve spring-centred	ms	50	85	40	75	35	70	30	65	
	2-position valve	ms	120	160	100	130	75	120	70	105	
	3-position valve hydraulic centred	o to a	ms	30	55	30	55	25	50	25	50
		o to b	ms	35	65	35	65	30	60	30	60
Shifting time of the valve from shifted position to neutral position	3-position spring-centred	ms	40-55	40	40-55	40	40-55	40	40-55	40	
	2-position valve	ms	35-50	45	35-50	45	30-45	40	30-45	35	
	3-position valve hydraulic centred	ms	30-50	30	30-50	30	30-50	30	30-50	30	

Nominal size 32 Ac (∼) and DC (=)											
Pilot pressure		MPa	7		14		21		25		
Voltage type			∼	=	∼	=	∼	=	∼	=	
Shifting time of the valve from neutral position to shifted position	3-position valve spring-centred	ms	65	80	50	90	35	105	41.5	80	
	2-position valve	ms	100	130	75	100	60	115	90	125	
	3-position valve hydraulic centred	o to a	ms	55	100	40	85	35	85	35	45
		o to b	ms	60	105	45	95	40	95	35	45
Shifting time of the valve from shifted position to neutral position	3-position spring-centred	ms	60-75	50	60-75	50	60-75	50	70	70	
	2-position valve	ms	115-130	90	85-100	70	65-80	65	80	85	
	3-position valve hydraulic centred	a to o	ms	30-65	30	60-90	30	105-155	50	60	60
		b to o	ms	30-65	30	60-90	30	105-155	50	60	660

Characteristic curves (measured at $v=41\text{mm}^2/\text{s}$ and $t=50^\circ\text{C}$)

4WEH10...

Symbol	Flow direction			
	P-A	P-B	A-T	B-T
E, Y D	2	2	4	5
F	1	4	1	4
G, T	4	2	2	6
H, C	4	4	1	4
J, K	1	4	1	4
L	2	3	1	4
M	4	4	3	4
P	4	1	3	4
Q, V W, Z	2	2	3	5
R	2	2	3	-
U	3	3	3	4

Symbol	Neutral position		
	A-T	B-T	P-T
F	3	-	3
G, T	-	-	7
H	1	3	5
L	3	-	-
P	-	7	5
U	-	4	-

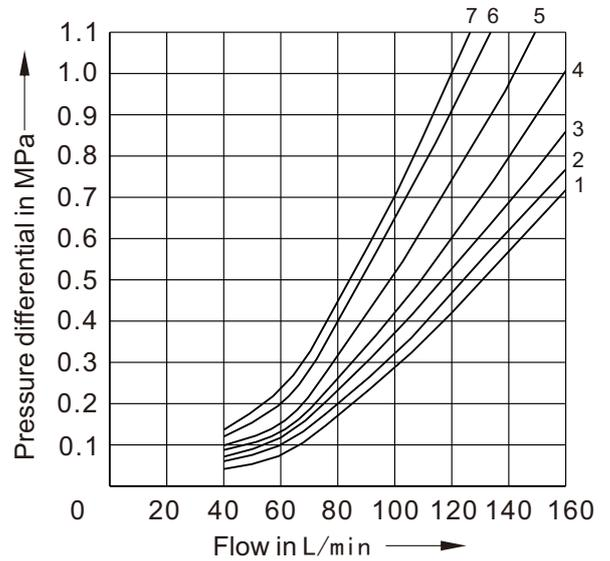

4WEH16...

Symbol	Flow direction				
	P-A	P-B	A-T	B-T	P-T
E, D, Y	1	1	1	3	-
F	2	2	2	3	-
G, T	5	1	3	7	6
H, C, Q, V, Z	2	2	3	3	-
J, K, L	1	1	3	3	-
M, W	2	2	4	3	-
R	2	2	4	-	-
U	1	1	4	7	-

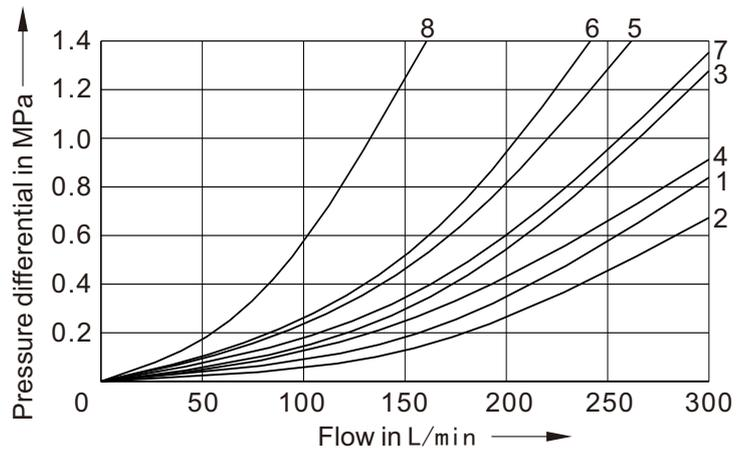

4WEH22...

Symbol	Flow direction			
	P-A	P-B	A-T	B-T
E, M, P Q, U, V	2	2	1	4
F	1	2	1	2
G, T	2	2	2	4
H, J, W	1	2	1	3
L	2	2	1	2
R	1	2	1	-

Symbol	Neutral position		
	A-T	B-T	P-T
F	-	-	4
G, P	-	-	6
H	-	-	2
L	4	-	-
T	-	-	5
U	-	6	-

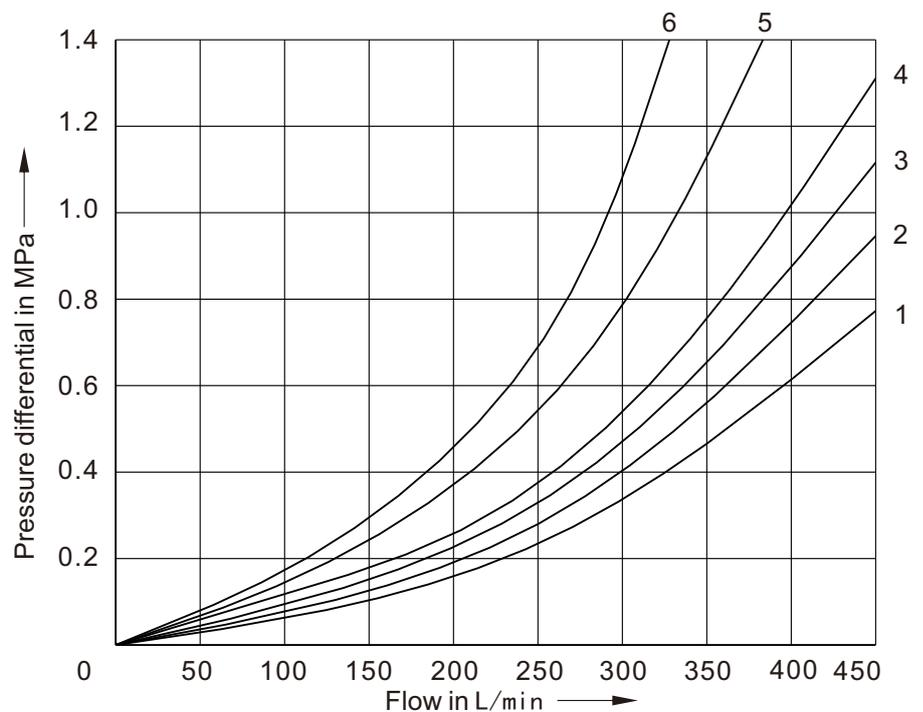

Characteristic curves (measured at $v=41\text{mm}^2/\text{s}$ and $t=50^\circ\text{C}$)

4WEH25...

Symbol	Flow direction			
	P-A	P-B	A-T	B-T
E	1	1	1	3
F	1	4	3	3
G	3	1	2	4
H	4	4	3	4
J、Q	2	2	3	5
L	2	2	3	3
M	4	4	1	4
P	4	1	1	5
R	2	1	1	-
U	4	1	1	6
V	2	4	3	6
W	1	1	1	3
T	3	1	2	4

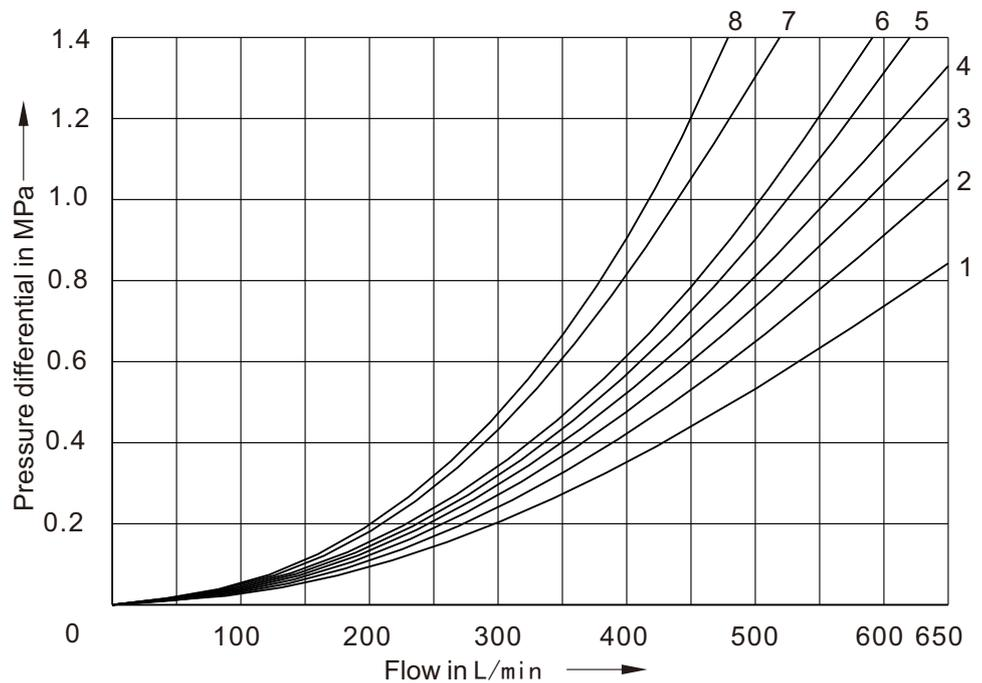

4WEH32...

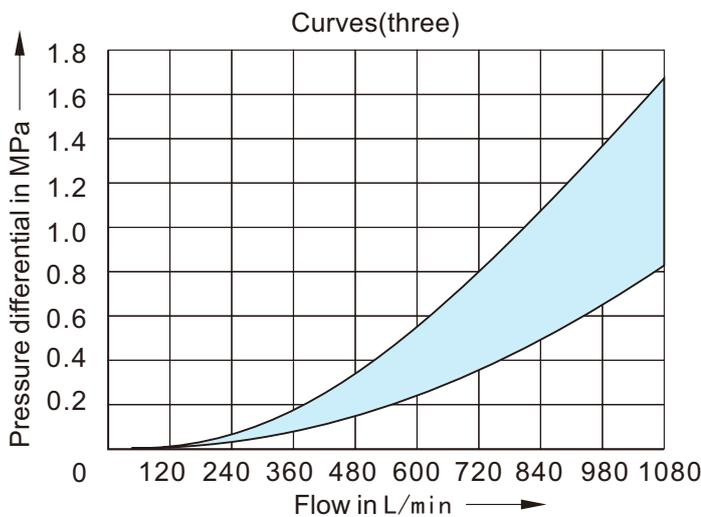
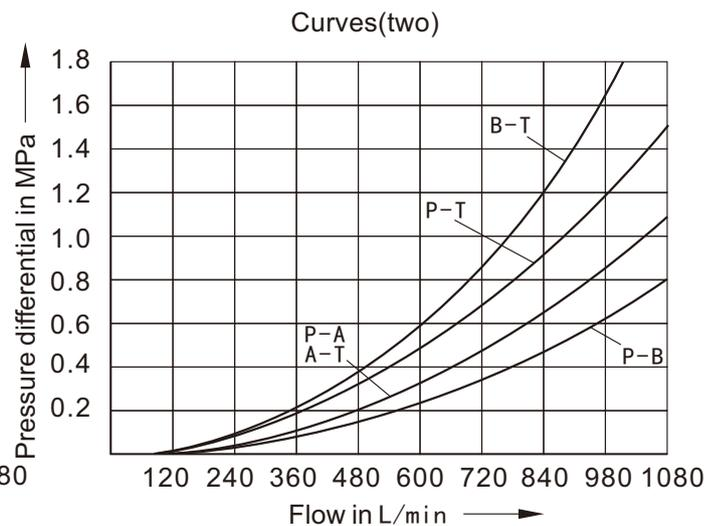
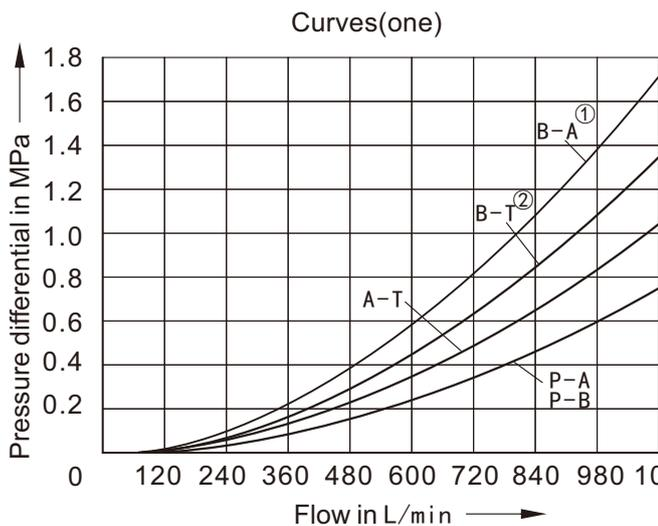

Note:

- Curves (one) for E, R, W spools
- Curves(two) for G and T spools
- Curves(three) for all spools
- ① Only for R spool
- ② Don't use for R spool

Shifting performance limits

4WEH10...

Spools	Flow L/min	Operating pressure in MPa		
		20	25	31.5
E, J, L, M, Q, R, U, V, W, C, D, K, Z, Y		160	160	160
H		160	150	120
G, T		160	160	140
F, P		160	140	120

4WEH16...

2-position valves permissible flow in L/min

	Symbol	Operating pressure in MPa				
		7	14	21	28	35
①	C	300	300	300	300	300
	D, Y	300	270	260	250	230
	K	300	250	240	230	210
	Z	300	260	190	180	160
Hydraulic return	HC, HD, HK HZ, HY	300	300	300	300	300

3-position valves permissible flow in L/min

	Symbol	Operating pressure in MPa				
		7	14	21	28	35
Main valve spring return	E, H, J, L, M Q, U, W, R	300	300	300	300	300
	F, P	300	250	180	170	150
	G, T	300	300	240	210	190
	S	300	300	300	250	220
	V	300	250	210	200	180
Hydraulic return	all spool	300	300	300	300	300

4WEH22...

2-position valves permissible flow in L/min

	Symbol	Operating pressure in MPa				
		7	14	21	28	35
Main① valve spring return	C	450	450	320	250	200
	D, Y	450	450	450	400	320
	K	450	215	150	120	100
	Z	350	300	290	260	160
Hydraulic return	HC,HD,HK HZ, HY	450	450	450	450	450
	HC.../O ...	450	450	450	450	450
	HD.../O ...	450	450	450	450	450
	HK.../O ...	450	450	450	450	450
	HZ.../O ...	450	450	450	450	450
	HC.../OF...	450	450	450	450	450
	HC.../OF...	450	450	450	450	450
	HC.../OF...	450	450	450	450	450
	HC.../OF...	450	450	450	450	450
	HC.../OF...	450	450	450	450	450

4WEH/4WH...

Note:

- Data of left table is only fit for flowing to two direction at the same time. For single flow direction(for example:P to A, B plugged),the permit flow is reduced obviously.Please contract with our company's technical dep. for detail information.
- The power limit is measured under solenoid on work temperature, 10% return voltage and without return oil back pressure.

Note:

- ① Showing flow data is the limit data of driving spool back to end position when pilot pressure disappear.
- Main valve spring return and pilot oil supply external type. Main valve permit flow is 300 L/min within adjustment pressure range when smallest pilot control oil pressure is 1.2MPa.
- If using pilot oil supply internal type and flow is smaller than 160L/min, it needs to install prefill valve on main valve P port for C, D, Y, K, Z, HC, HD, HK, HZ, HY spools.

Note:

- It must improve control pressure when using 3-position,4-pass direction valve of main spool spring centred and using pressure more than limit. For example,work pressure is 35MPa, flow is 300L/min,pilot control pressure should be 1.6MPa.
- It needs to install prefill valve at P port when V type spool's flow for pilot oil supply external and hydraulic centred smaller than 160L/min.
- If using pilot oil supply internal type, It needs to install prefill valve at P port for F,G,M,P,S spools .

3-position valves permissible flow in L/min

	Symbol	Operating pressure in MPa				
		7	14	21	28	35
Main valve spring return	E, J, L, M Q, U, W	450	450	450	450	450
	H	450	450	300	260	230
	G	400	350	250	200	180
	F	450	270	175	130	110
	V	450	300	240	220	160
	T	400	300	240	200	160
	P	450	270	180	170	110

Note:

- ① Showing flow data is the limit data of driving spool back to end position when pilot pressure disappear.
- If using pilot oil supply internal type and flow is smaller than 160L/min, it needs to install prefill valve on main valve P port for F, G, M, P, T spools.

Shifting performance limits

4WEH25...

2-position valves permissible flow in L/min

	Symbol	Operating pressure in MPa				
		7	14	21	28	35
Spring return ①	C	700	700	700	700	650
	D、Y	700	650	400	350	300
	K	700	650	420	370	320
	Z	700	700	650	480	400
Hydraulic centred	HC、HD、HK HZ、HY	700	700	700	700	700
	HC../O	700	700	700	700	700
	HD../O	700	700	700	700	700
	HK../O	700	700	700	700	700
	HZ../O	700	700	700	700	700
	HC../OF	700	700	700	700	700
	HC../OF	700	700	700	700	700
	HC../OF	700	700	700	700	700
	HC../OF	700	700	700	700	700
	HC../OF	700	700	700	700	700

Note:

- ① Showing flow data is the limit data of driving spool back to end position when pilot pressure disappear.
- If using pilot oil supply internal type and flow is smaller than 180L/min, it needs to install prefill valve on main valve P port for H、HZ、V、C、HC、F、P、T spools.

3-position valves permissible flow in L/min

	Symbol	Operating pressure in MPa				
		7	14	21	28	35
Spring centred	E、L、M、 Q、U、W	700	700	700	700	650
	G、T	400	400	400	400	400
	F	650	550	430	330	300
	H	700	650	550	400	360
	J	700	700	650	600	520
	P	650	550	430	330	300
	V	650	550	400	350	310
Hydraulic centred	E、F、H、J L、M、P、Q R、U、V、W	700	700	700	700	650
	G、T	400	400	400	400	400
Hydraulic centred	G、T	700	700	700	700	650

- Main valve spring return and choosing pilot oil supply external type. Main valve permit flow is 700L/min under 28MPa when smallest pilot control oil pressure is 1.3MPa. The flow should be 650L/min when pressure is 35MPa.

4WEH32...

2-position valves permissible flow in L/min

	Symbol	Operating pressure in MPa				
		7	14	21	28	35
Spring return ①	C、D、K、 Z、Y	1100	1040	860	750	680
Spring return ②	C	1100	1040	860	800	680
	D、Y	1100	1040	540	480	680
	K	1100	1040	860	500	680
	Z	1100	1040	860	700	680
Hydraulic return	HC、HD、HK HZ、HY	1100	1040	860	750	680

Note:

- ① Showing flow data is the limit data of driving spool back to end position when pilot pressure disappear.
- ② Main valve spring return and choosing pilot oil supply external type. Main valve permit flow is 700L/min under 28MPa when smallest pilot control oil pressure is 1.0MPa.
- If using pilot oil supply internal type and flow is smaller than 180L/min, it needs to install prefill valve on main valve P port for Z、HZ、V spools.

3-position valves permissible flow in L/min

	Symbol	Operating pressure in MPa				
		7	14	21	28	35
Spring centred	E、J、L、M Q、U、W、R	1100	1040	860	750	680
	G、T、F、P、 H	900	900	800	650	450
	V	1100	1000	680	500	450
Hydraulic centred	all spool	1100	1040	860	750	680

- It must improve control pressure when using 3-position, 4-pass direction valve of main spool spring centred and using pressure more than limit. For example, work pressure is 35MPa, flow is 1100L/min, pilot control pressure should be 1.6MPa.
- If using pilot oil supply internal type and flow is smaller than 180L/min, it needs to install prefill valve on main valve P port for C、HC、F、G、H、P、T spools.

Installation Dimensions 4WEH10...

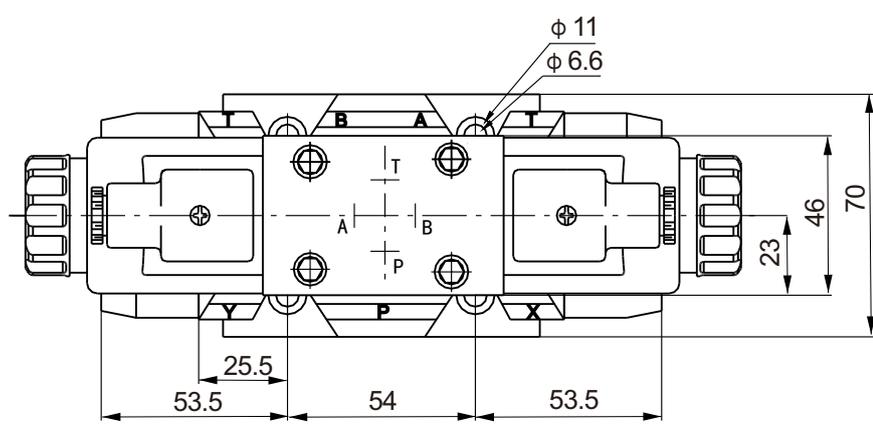
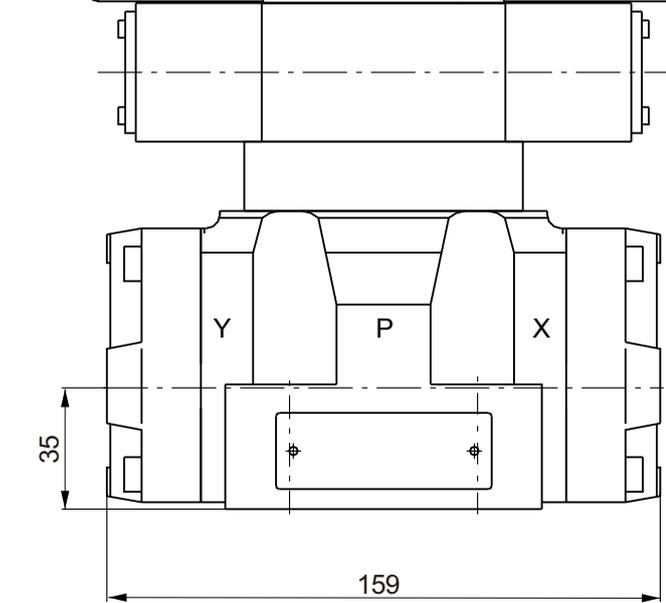
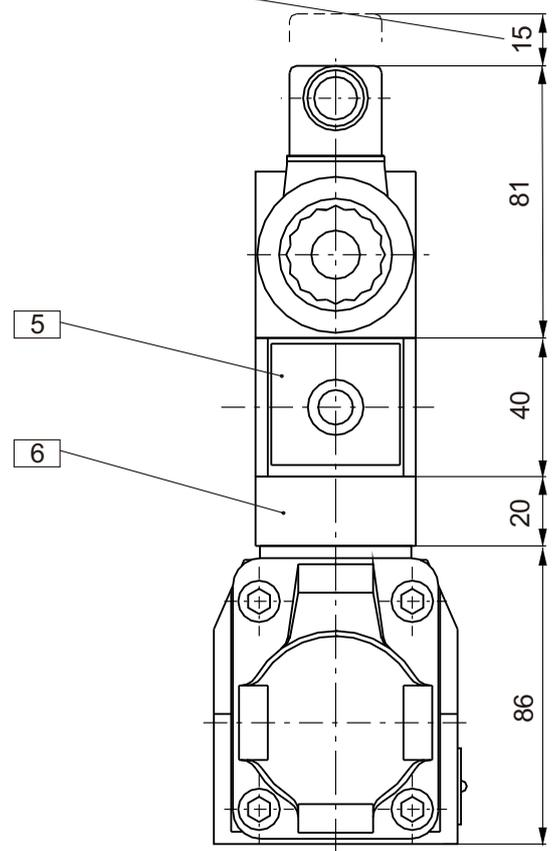
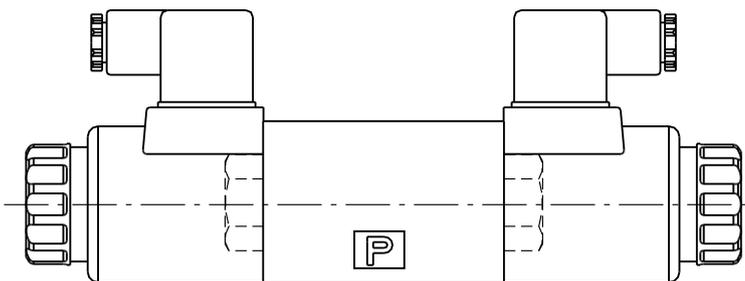
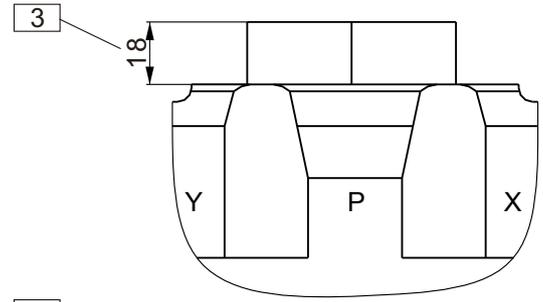
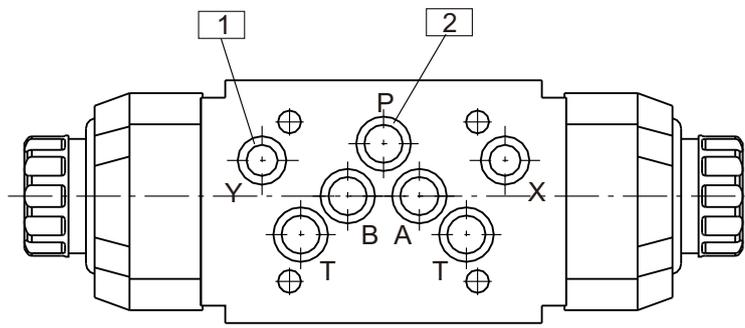

Explanation

- 1.O Ring 2-10.6x1.8 ;
- 2.O Ring 5-12x2 ;
- 3.Connection subplate thickness for hydraulic operate (4WH...);
- 4.Space for pulling out plug ;
- 5.Shifting time adjustment ;
- 6.reducing valve ;

Valve fix bolts

4-M6x45 GB/T70. 1-2000-12. 9, M_A=15. 5N. M

Installation Dimensions 4WEH16...

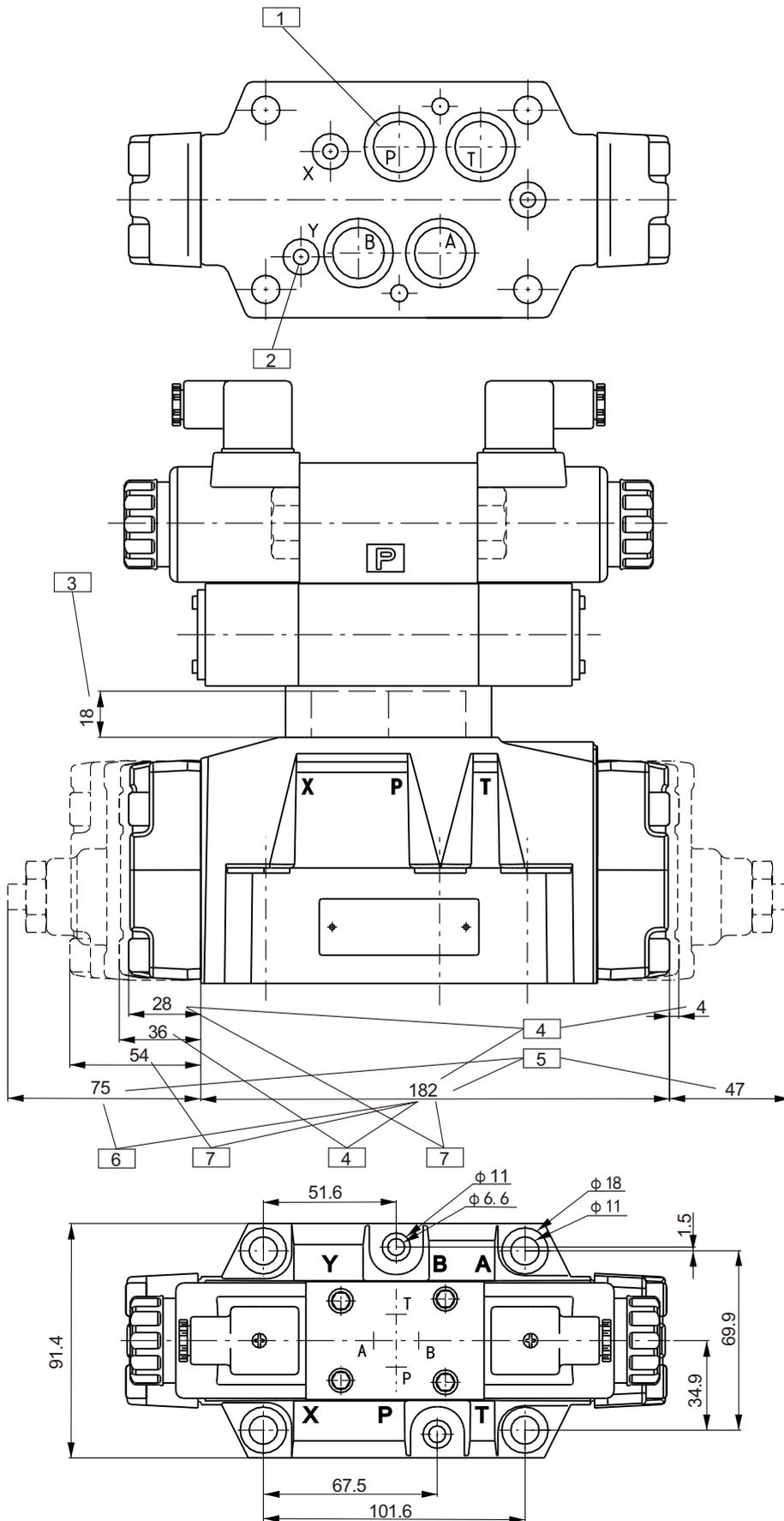

Valve fix bolts

4-M10x60 GB/T70.1-2000-12.9,
 M_A=75N.M
 2-M6x60 GB/T70.1-2000-12.9,
 M_A=15.5N.M

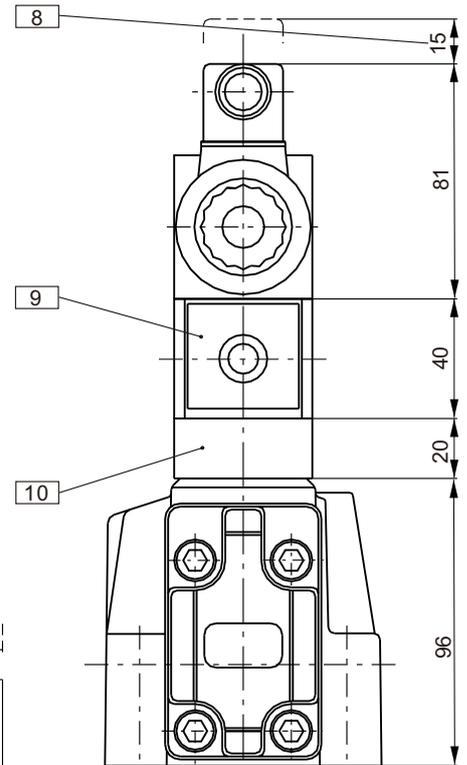

Explanation

- 1.O Ring 4-22.4x2.65 ;
- 2.O Ring 2-9.8x2.4 ;
- 3.Connection subplate thickness for hydraulic operate (4WH...);
- 4.2-position valve for main valve spring deflection ;
- 5.Space for pulling out plug ;
- 6.Moving space adjustment ;
- 7.3-position valve, spring centred ;
2-position valve, main valve hydraulic return ;
- 8.Space for pulling out plug ;
- 9.Shifting time adjustment ;
- 10.reducing valve ;

Installation Dimensions 4WEH22...

Valve fix bolts

6-M12x60 GB/T70.1-2000-12.9,
M_A=150N.M

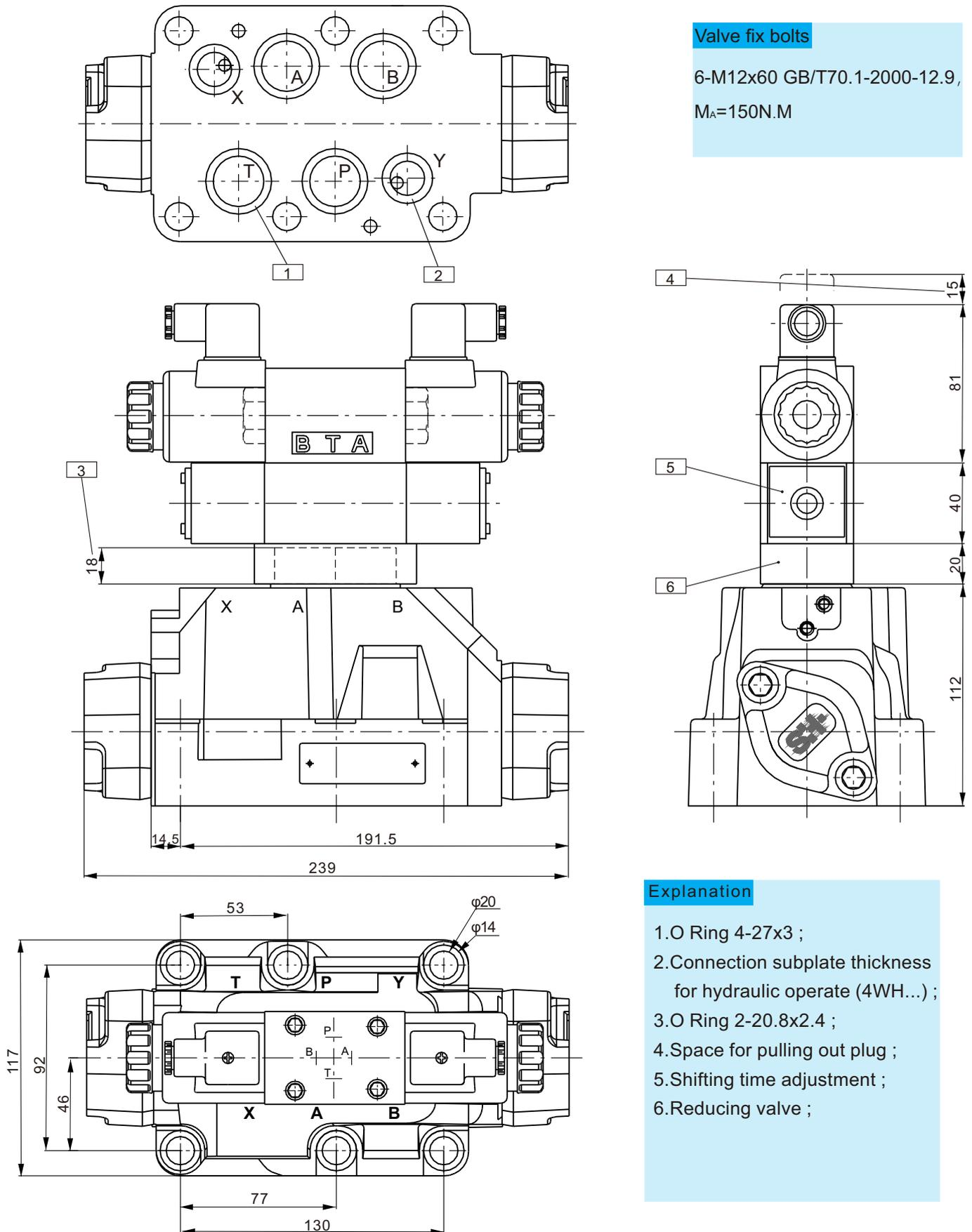

Installation Dimensions 4WEH25...

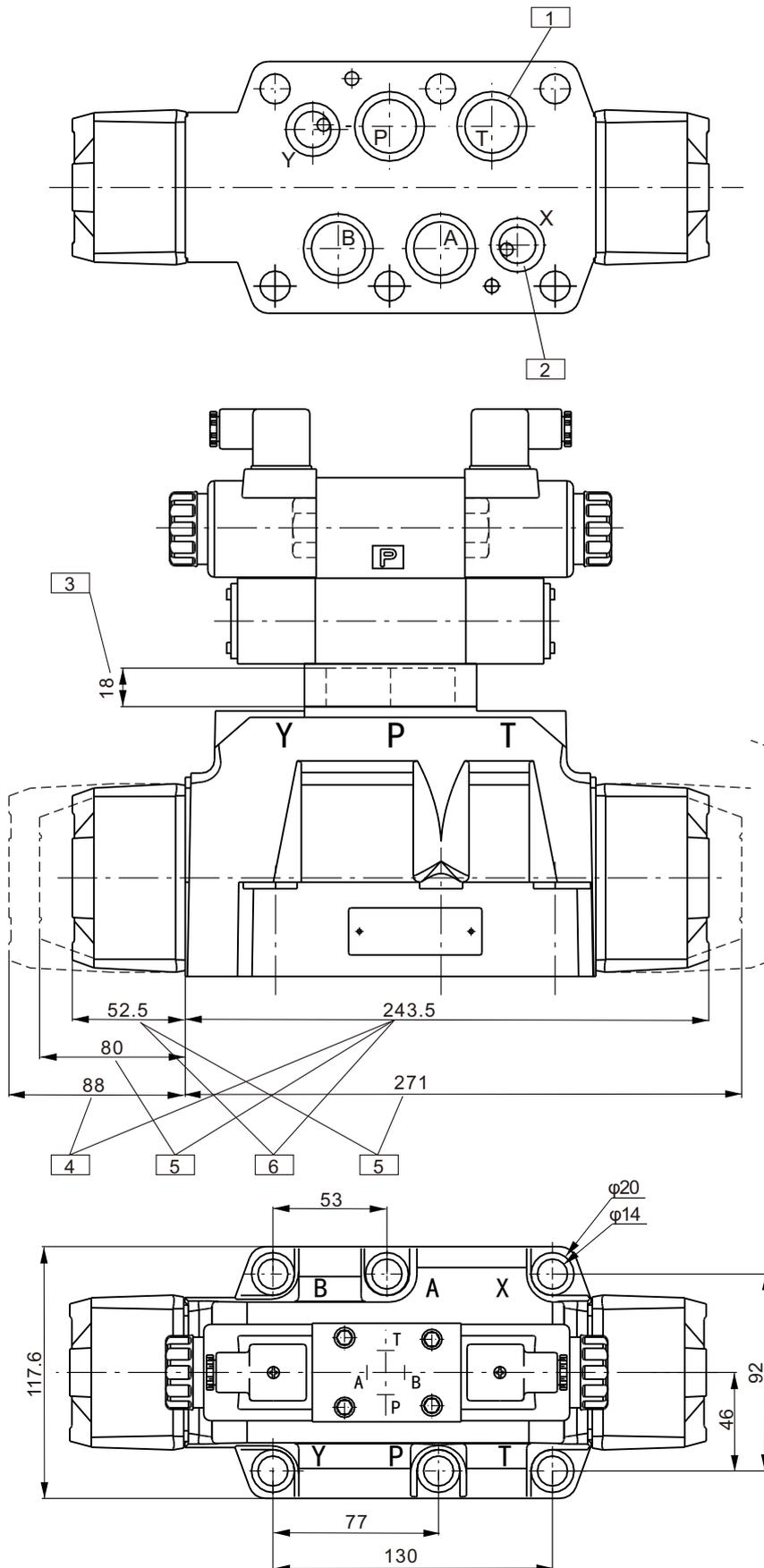

Valve fix bolts

6-M12x60
 GB/T70.1-2000-12.9,
 $M_A=130N.M$

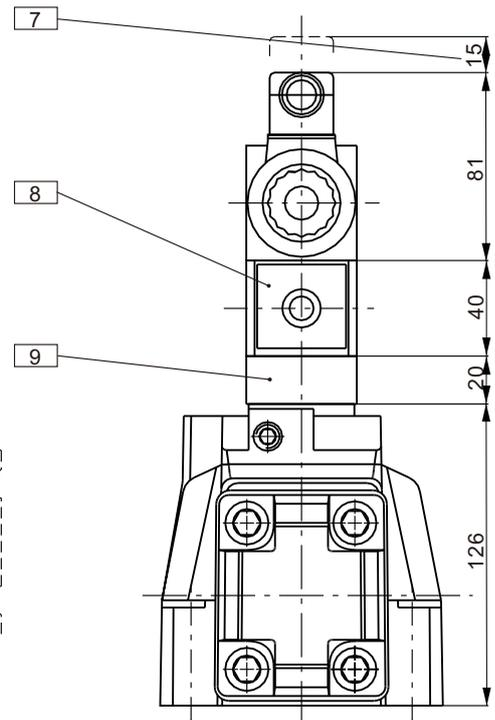

Explanation

- 1.Connection subplate thickness for hydraulic operate (4WH...);
- 2.3-position valve, pressure centred
- 3.2-position valve for main valve spring deflection;
- 4.3-position valve, spring centred;
- 5.2-position valve, main valve hydraulic return;
- 6.O Ring 4-29.7x3.5
- 7.Space for pulling out plug;
- 8.Shifting time adjustment;
- 9.reducing valve;

Installation Dimensions 4WEH32...

Valve fix bolts

6-M20x80 GB/T70.1-2000
-12.9, $M_A=430\text{N.M}$

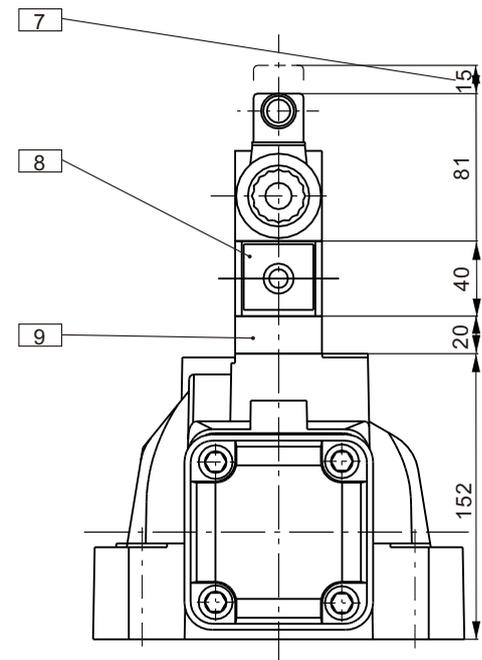
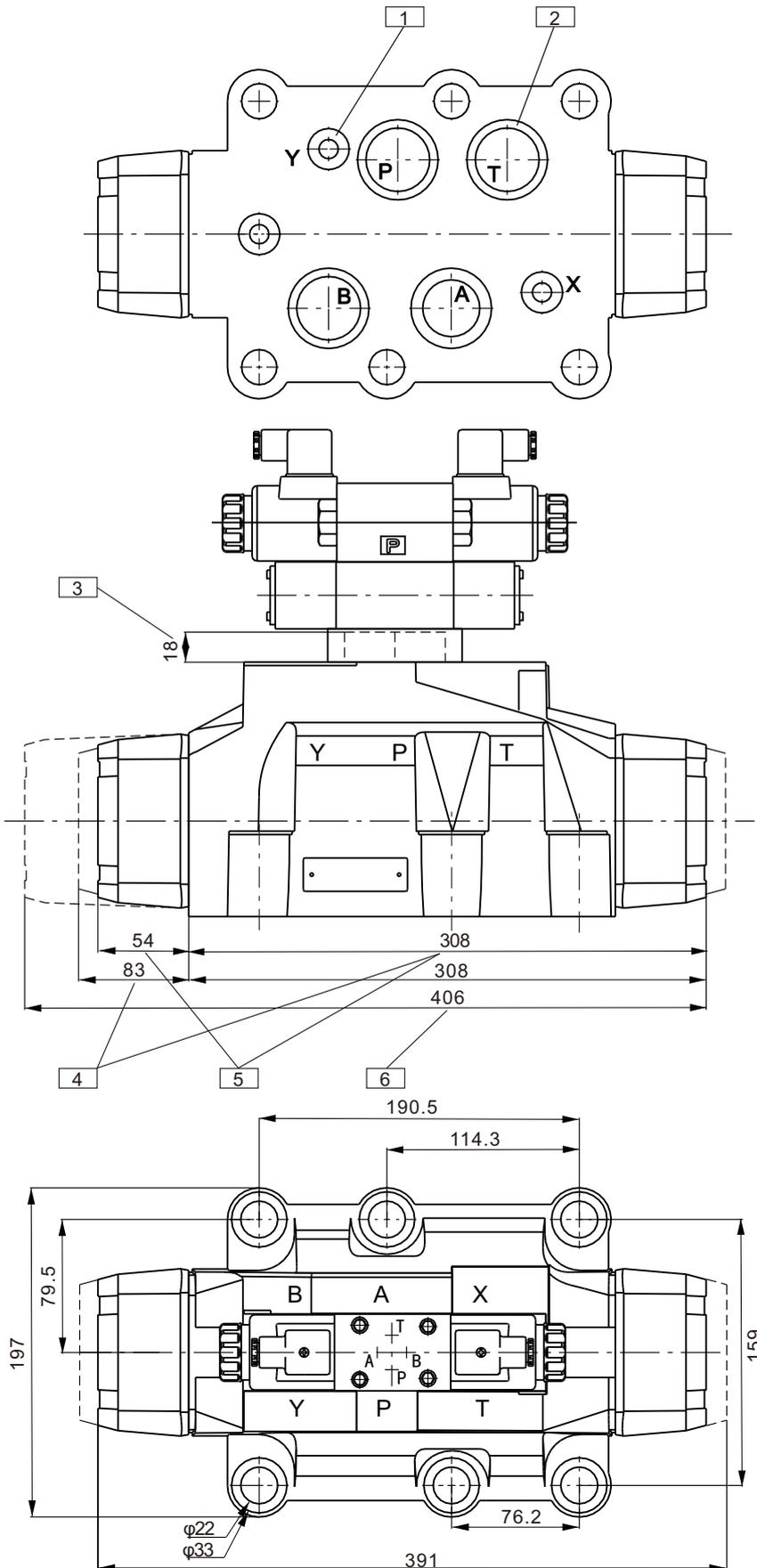

Explanation

1. O Ring 3-19x3 ;
2. Connection subplate thickness for hydraulic operate (4WH...);
3. 2-position valve for main valve spring deflection ;
4. 3-position valve, spring centred ;
2-position valve, main valve hydraulic return ;
5. 3-position valve, pressure centred
6. O Ring 4-42x3 ;
7. Space for pulling out plug ;
8. Shifting time adjustment ;
9. reducing valve ;

Subplate Installation Dimensions

4WEH10/4WH10

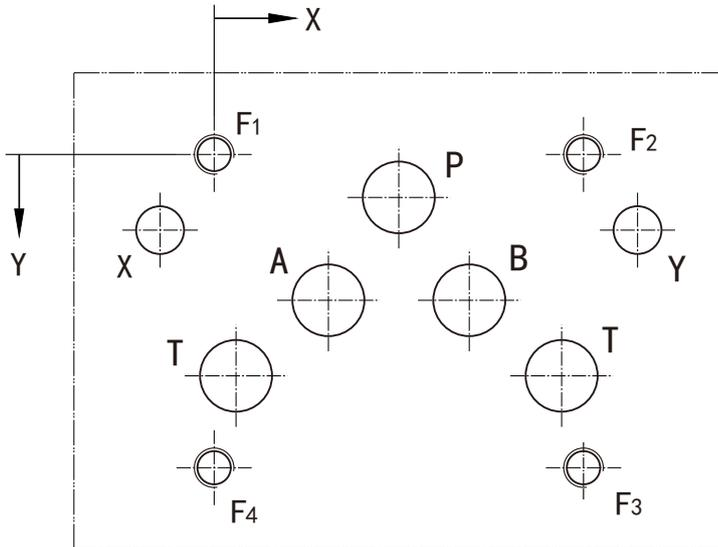

4WEH16/4WH16

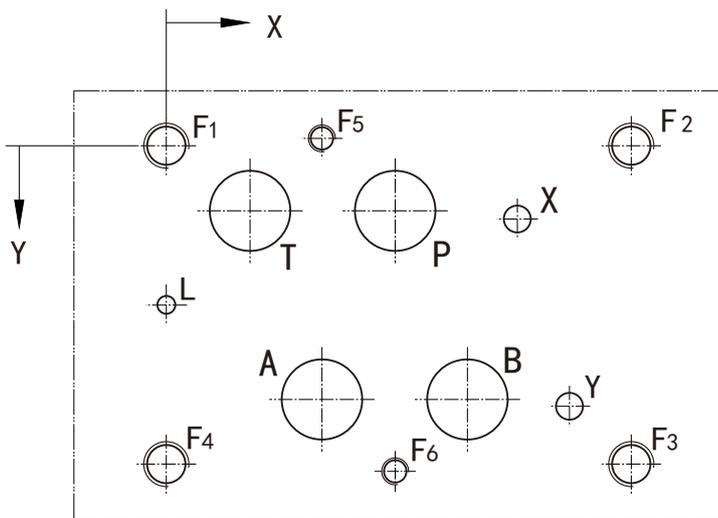

4WEH22/4WH22

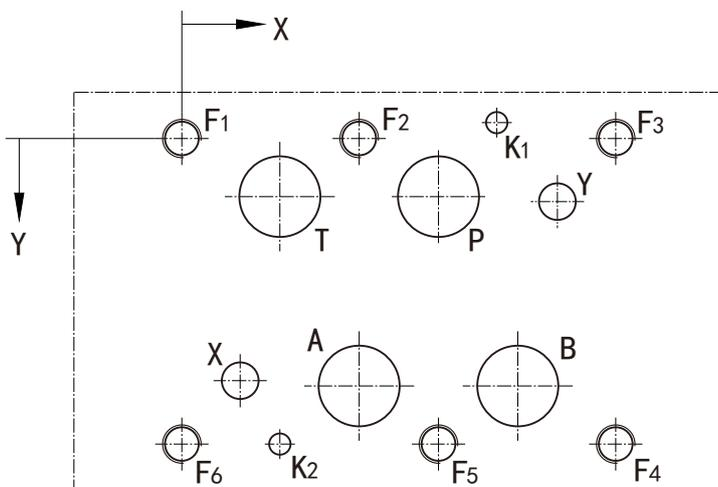

Size	Des. Code	Position		Character	
		X	Y		Deep
4WEH10/4WH10	F1	0	0	M6	12
	F2	54	0	M6	12
	F3	54	46	M6	12
	F4	0	46	M6	12
	P	27	6.3	φ 10.5	–
	A	16.7	21.4	φ 10.5	–
	B	37.3	21.4	φ 10.5	–
	T	3.2	32.5	φ 10.5	–
		50.8			
	X	-7.9	11.1	φ 7	–
Y	61.9	11.1	φ 7	–	
4WEH16/4WH16	F1	0	0	M10	19
	F2	101.6	0	M10	19
	F3	101.6	69.9	M10	19
	F4	0	69.9	M10	19
	F5	34.1	-1.6	M6	12
	F6	50	71.5	M6	12
	L	0	35	φ 4	–
	T	18.3	55.6	φ 17.5	–
	A	34	14.2	φ 17.5	–
	P	50	55.6	φ 17.5	–
	B	65.8	14.2	φ 17.5	–
	X	76.7	53.8	φ 6	–
Y	88.1	12.7	φ 6	–	
4WEH22/4WH22	F1	0	0	M12	24
	F2	53.2	0	M12	24
	F3	130.2	0	M12	24
	F4	130.2	92.1	M12	24
	F5	77	92.1	M12	24
	F6	0	92.1	M12	24
	K1	94.5	-4.8	φ 6.5	8
	K2	29.4	92.1	φ 6.5	8
	T	29.4	17.5	φ 24.5	–
	A	53.2	74.6	φ 24.5	–
	B	100.8	74.6	φ 24.5	–
	P	77	17.5	φ 22	–
	X	17.5	73	φ 11.2	–
	Y	112.7	19	φ 11.2	–

Subplate Installation Dimensions

4WEH25/4WH25

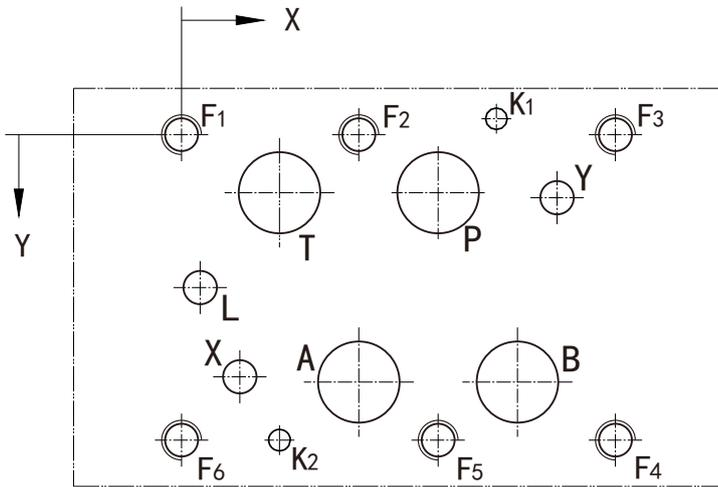

4WEH32/4WH32

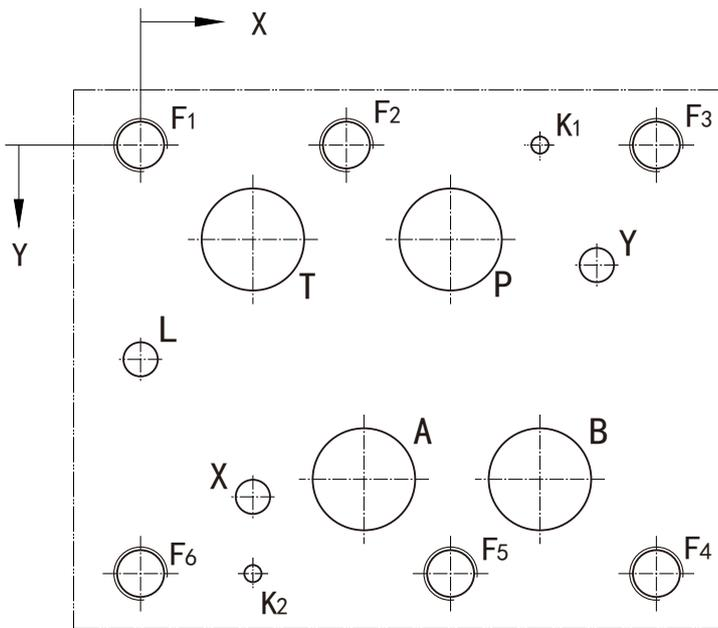

Required Process Precision

Size	Des. Code	Position		Character	
		X	Y		Deep
4WEH25/4WH25	F1	0	0	M12	24
	F2	53.2	0	M12	24
	F3	130.2	0	M12	24
	F4	130.2	92.1	M12	24
	F5	77	92.1	M12	24
	F6	0	92.1	M12	24
	L	5.6	-4.8	φ10	-
	K1	94.5	-4.8	φ6.5	8
	K2	29.4	92.1	φ6.5	8
	T	29.4	17.5	φ24.5	-
	A	53.2	74.6	φ24.5	-
	B	100.8	74.6	φ24.5	-
	P	77	17.5	φ22	-
	X	17.5	73	φ11.2	-
Y	112.7	19	φ11.2	-	
4WEH32/4WH32	F1	0	0	M20	35
	F2	76	0	M20	35
	F3	190.5	0	M20	35
	F4	190.5	159	M20	35
	F5	114.5	159	M20	35
	F6	0	159	M20	35
	L	0	79.7	φ13	-
	K1	147.5	0	φ6.5	8
	K2	41.5	159	φ6.5	8
	T	41.5	35	φ35	-
	A	82.5	124	φ35	-
	B	147.5	124	φ35	-
	P	114.5	35	φ34	-
	X	41.5	130.5	φ13	-
Y	168.5	44.5	φ13	-	