

Proportional Pressure Relief Valves Direct Operated Type EDG...

■ Product show and brief introduction

Size 01
Component series 10/20
Maximum operating pressure 25 MPa
Maximum flow 2L/min

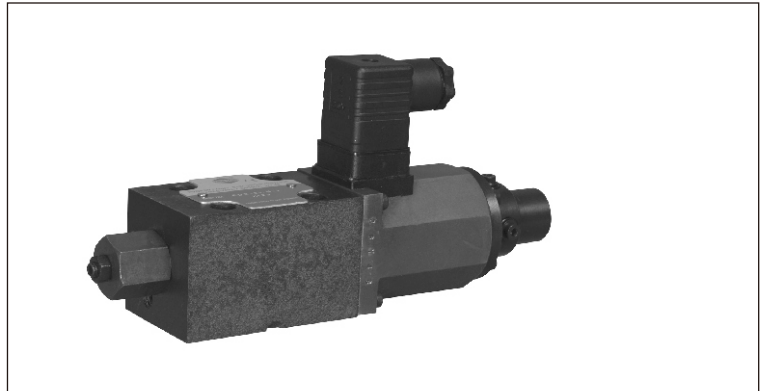

■ Features

- They can adjust system pressure proportionally base on input electricity of proportional solenoids.
- It's flow is small nad usually is used as pilot valve for system pressure telecontrol valve and other valves.
- The unloading when pressure is over loading can be come true by installing safe insert file , then it can protect proportional solenoid and system .

Ordering details

1	2	3	4	5	6	7	8	9
EDG	01							

Item	Collocate	Code	Explanation
1	Sort	EDG	Direct operated proportional pressure relief valve
2	Size	01	
3	Pressure Adjustment Range	B	0.5–6.9MPa
		C	1.0–15.7MPa
		H	1.2–24.5MPa
4	Over loading Protection	NO	No safe valve
		1	With safe valve
5	Inlet Throttle	NO	P port without throttle
		P08	P port with ϕ 0.8mm throttle
		P10	P port with ϕ 1.0mm throttle
		P12	P port with ϕ 1.2mm throttle
6	Outlet Throttle	NO	T port without throttle
		T10	T port with ϕ 1.0mm throttle
		T12	T port with ϕ 1.2mm throttle
		T14	T port with ϕ 1.4mm throttle
7	Design Series	10	Could`'t install safe valve
		20	Could with safe valve
8	Seal ²⁾ Material	NO	NBR
		V	FKM
9			Describe other especial demand

Note:

- 1) For other dimensions throttle controller ,please contact with our company`s technical dep. .
- 2)Please see page 6 on catalog for hydraulic fluid and seal material .

Symbols

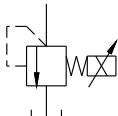
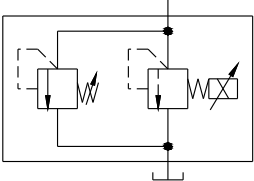
No safe valve	With safe valve
	

Work theory

EDG-01-.....-20

Input control electricity into proportional solenoid coil, output power pass to spool 3 from compress spring 2.

To compare hydraulic power on spool, it starts to relief after daff spool when hydraulic power bigger than solenoid power. Otherwise, the valve port will be closed.

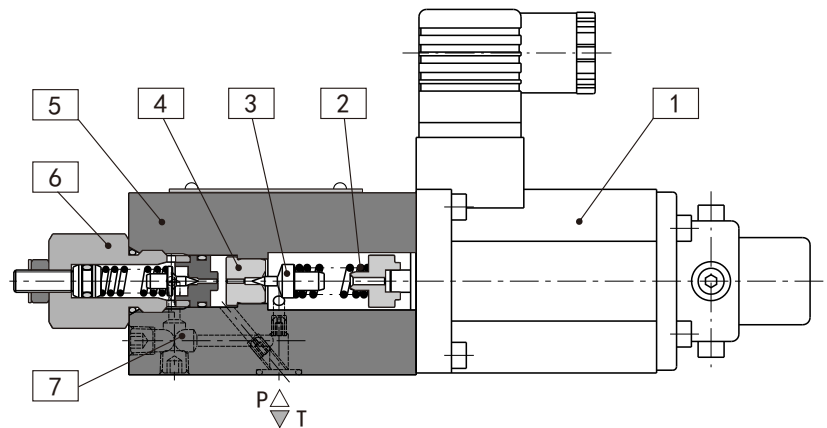

EDG-01-.....-10

The valve can be installed safe valve insert file 6(only for 20 design number type). Oil via pass road 7 to T port and reflow to oil box after opening safe valve's spool when oil pressure bigger than enactment value of safe vavle. There is production when system pressure over load rating.

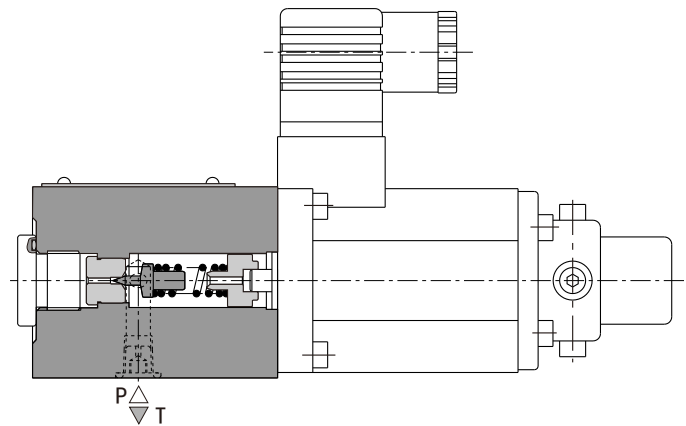

Technical data

Data		EDG-01-B	EDG-01-C	EDG-01-H
Rating electricity	mA	800	900	950
Max. Pressure	MPa	24.5		
Max.flow	L/min	2		
Min.flow	L/min	0.3		
Pressure adjustment range	Mpa	See model code		
Coil resistance	Ω	10		
Stagnant loop		< 3%		
Repeat precision		1%		
Weight	Kg	2.0		

Characteristic curves

Measure condition for below curves: flow 2L/min
 Obturation fluid vol. 40cm³ viscoce 30mm²/s

**Input electricity-pressure
Characteristic curve**

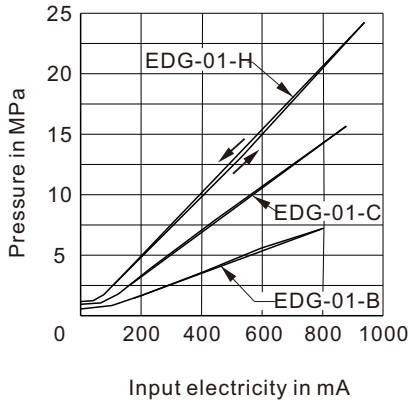

**Min. Enactment pressure
Characteristic curve**

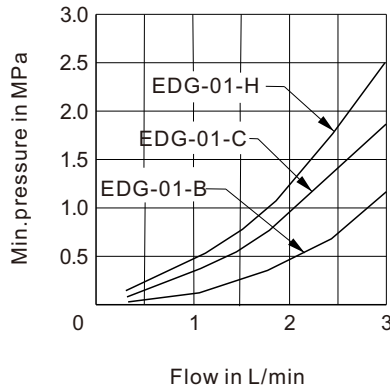

**Flow-pressure
Characteristic curve**

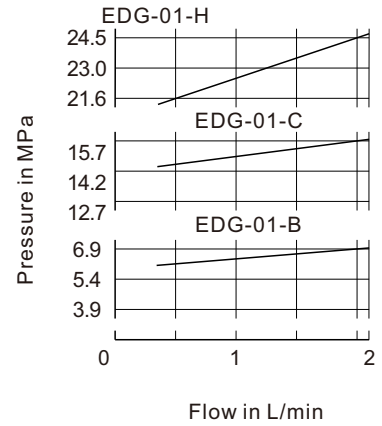

Pressure jumping response characteristic curves

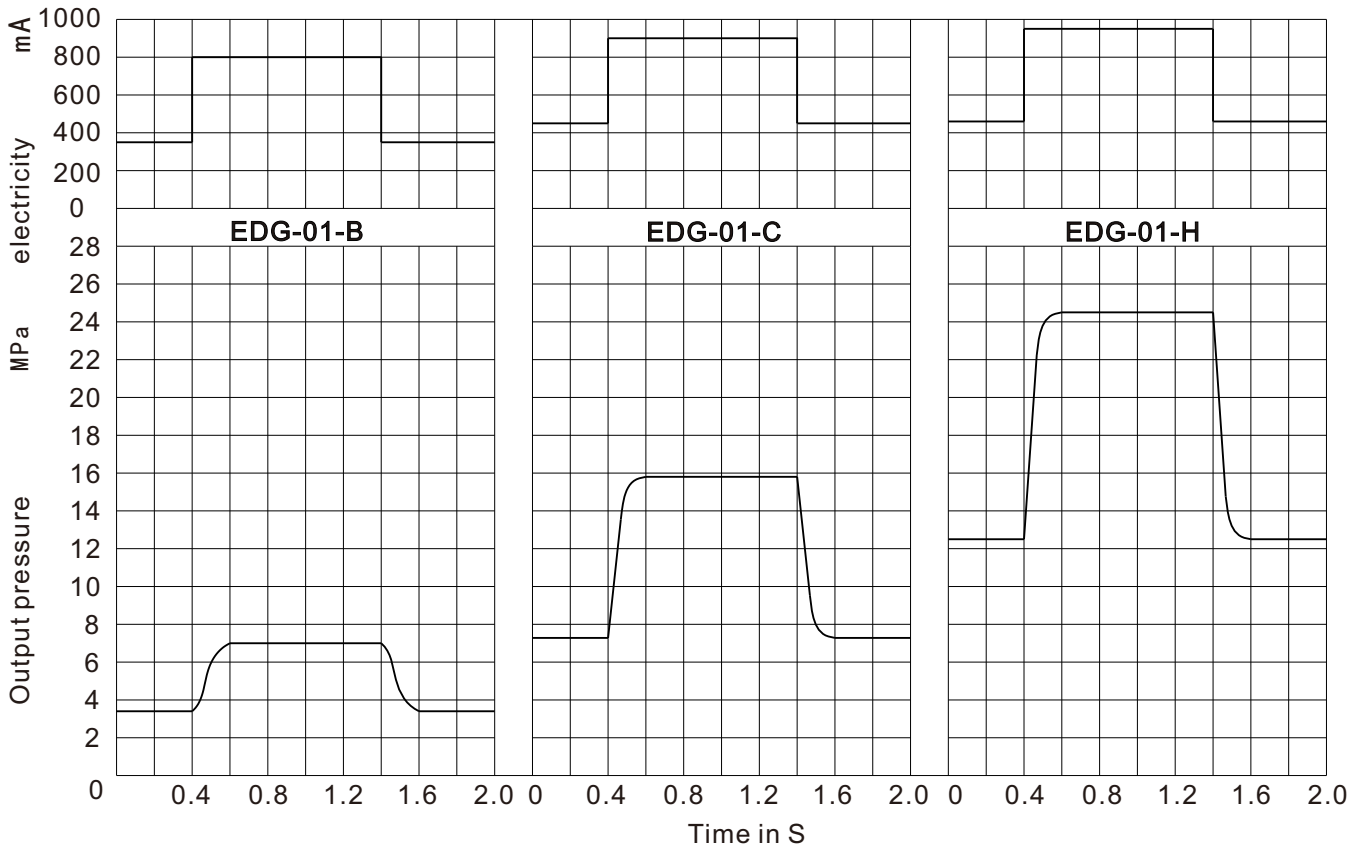

Installation dimensions

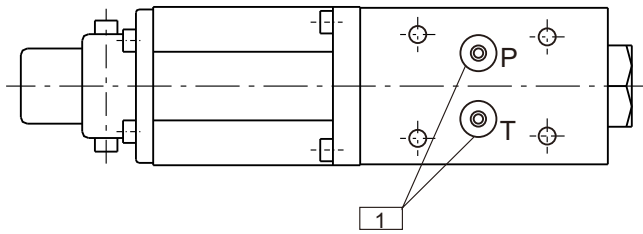

0.01/100
 $\sqrt{R_{max}4}$
 Required Process Precision

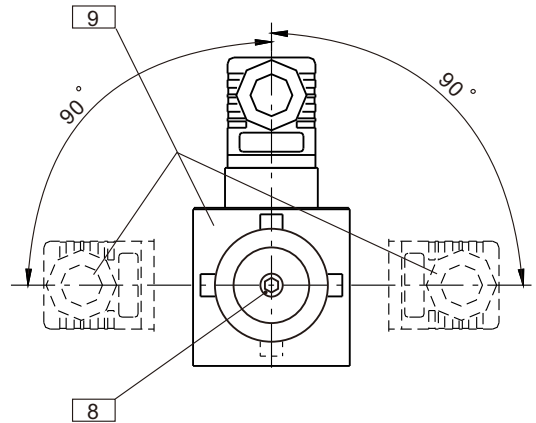
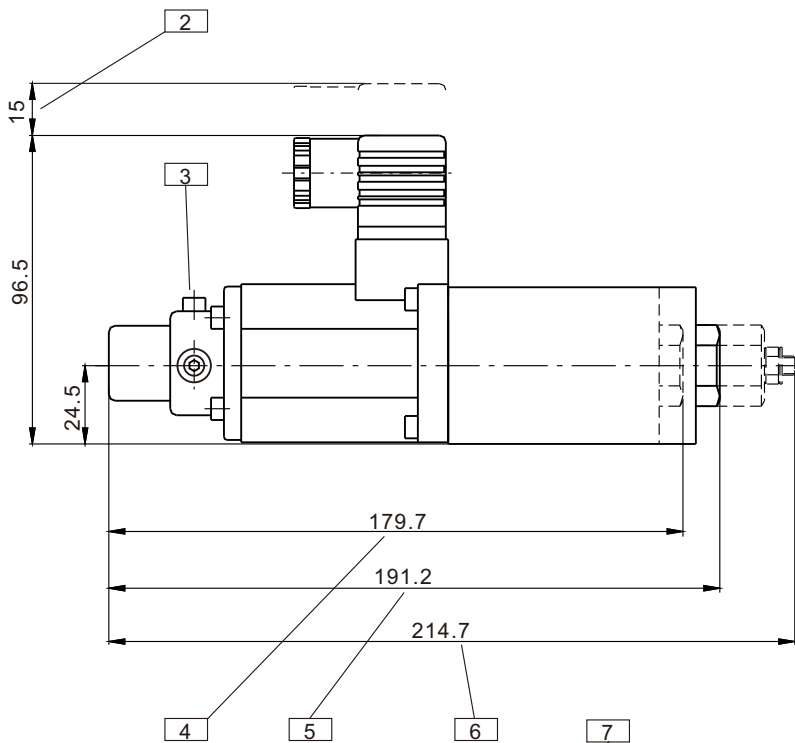

Valve fix bolts

4-M5x45 GB/T70.1-2000-12.9,
 $M_A=15.5N.M$

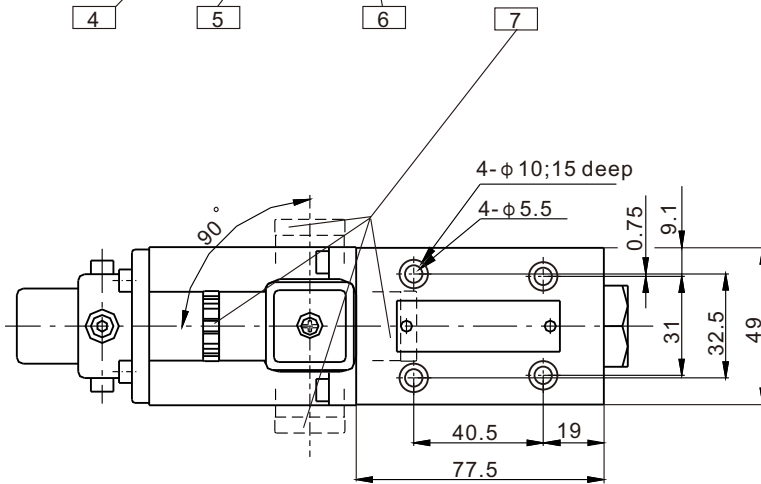

Explanation

- 1.O-RING 2-8.8x1.9
- 2.Space for pulling out plug
- 3.Vent(inside six corners=3)
- 4.For 10 design number valve,
It can't install safe valve.
- 5.For 20 design number valve,
It can install safe valve.
- 6.Space for safe valve
- 7.Plug installation direction
- 8.Manual pressure adjustment
Bolts \perp inside six corners=3 \perp
- 9.Installation for solenoid

Installation surface process dimensions

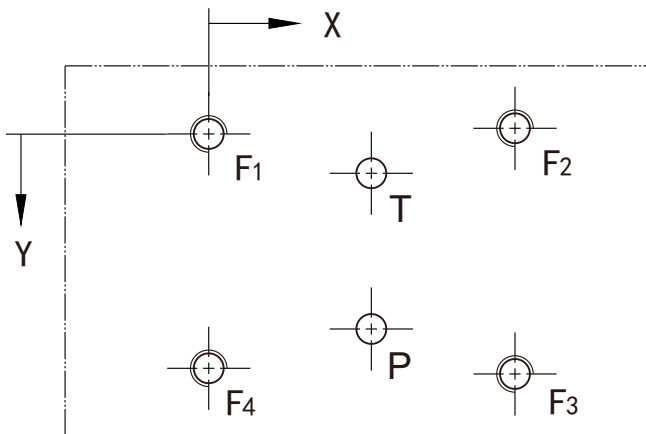

Size	DES. Code	Position		Character	
		X	Y		Deep
EDG01	F1	0	0	M5	10
	F2	40.5	-0.75	M5	10
	F3	40.5	31.75	M5	10
	F4	0	31	M5	10
	P	21.5	25.8	φ4	—
	T	21.5	5.2	φ4	—

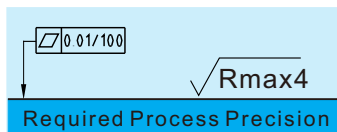

Note

The installation surface should be bigger Than valve bottom figure when process Valve's installation surface.

Installation and using notice

1. Unloading control

It needs connection pipe which inside dia. is 6mm and length is 300mm or more short when using the valve as relief valve to control unloading .If pressure isn't steady ,it needs to add φ1.0-1.5 throttle at oil outlet.

2. Return road pressure control

It needs to ensure that loading vol.(obturation fluid vol.) Is bigger than 40cm³ when using the valve to control return road pressure directly. Return oil pipe's back pressure should be smaller than 0.2MPa.

3. Safe valve's enactment pressure

Under max.flow, safe valve pressure is 2MPa(20.4kgf/cm) higher than max pressure adjustment range. If max work pressure is lower or using different max flow, it needs to adjust after working out safe valve's pressure enactment follow below formula. Pressure enactment value= (work pressure upper limit) + (additional pressure for right photo show) .

Additional pressure-flow curve

